

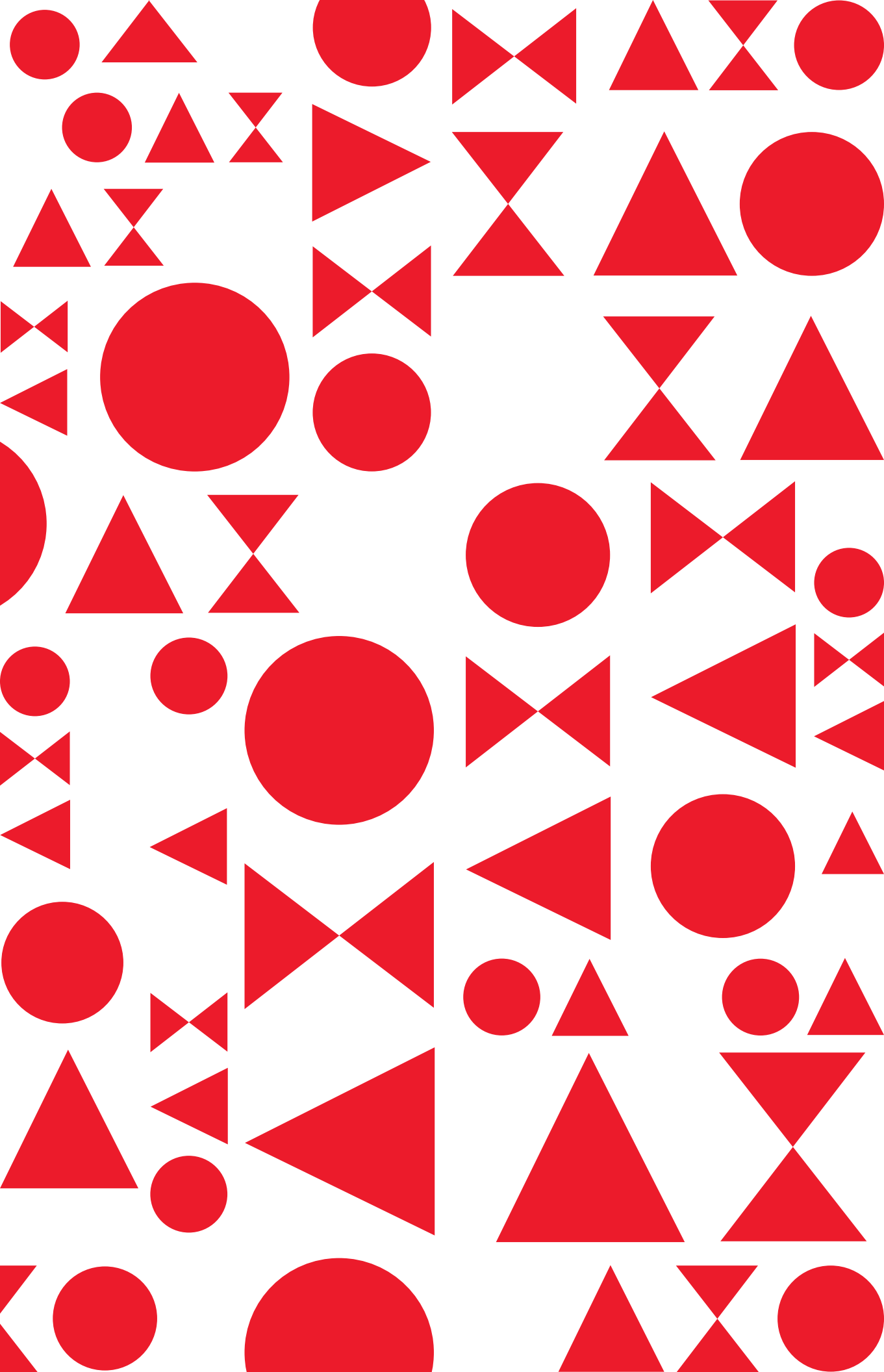

**CATALOGUE**

**2017/18**



**Axolight** bespoke  
design

2017/18



bespoke  
design

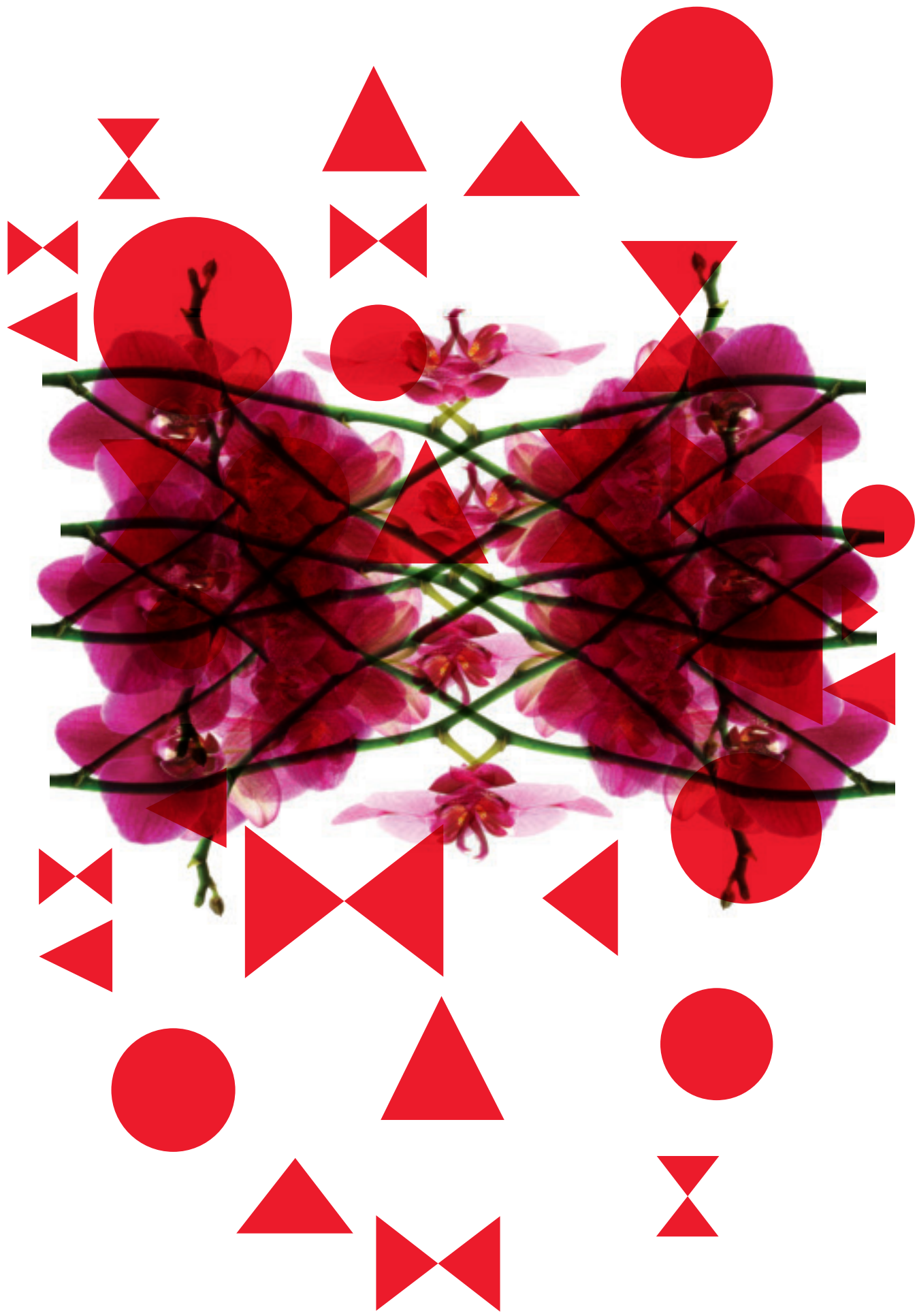

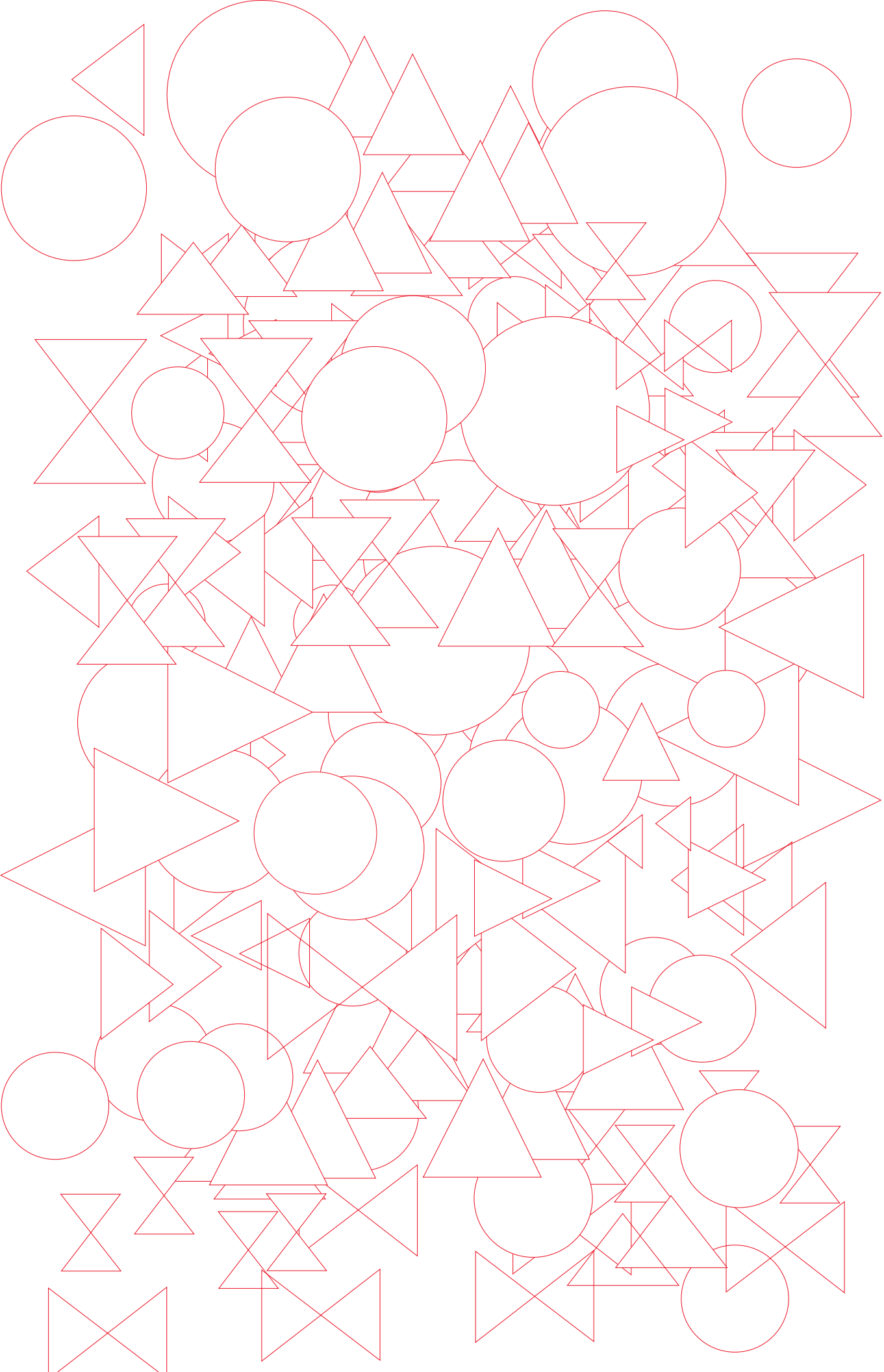

## LIST OF PRODUCTS

SUSPENSION



Alrisha  
6-7



Alysoid  
8-11



Aura  
12-13



Ax 20  
14-15



Bell  
16-19



Clavius  
20-21



Explo  
22-23



Fairy  
24-27



Fedora  
28-29



Hoops  
30-31



Melting Pot  
32-33



Mountain View  
34-35



Muse  
36-37



Nafir  
38-39



Orchid  
40-45



Rythmos  
46-47



Skin  
48-49



Skirt  
50-53



Spillray  
54-57



Spiry  
58



Stilla  
59



Urban  
60-61



Urban Mini  
62-63



Velvet  
64-65



Virtus  
66-67

WALL



Alrisha  
70



Aura  
71



Ax 20  
72-73



Clavius  
74-75



Fairy  
76-77



Lik  
78-79



Melting Pot  
80-81



Momus Mini  
82-83



Orchid  
84-85



Polia LED  
86-87



Rythmos  
88



Shatter LED  
89



Skirt  
90-91



Spillray  
92-93



U-light  
94-95



Uriel  
96-97



Vasily  
98



Voluptas  
99

WALL & CEILING



Ax 20  
102-103



Favilla  
104-105



Muse  
106-107



Necky  
108-109



Nelly  
110



Nelly Straight  
111



Orchid  
112-113



Stormy  
114-115



Ukiyo  
116-117

**CEILING**



Aura  
120-121



Bell  
122-125



Clavius  
126-127



Fairy  
128



Hoops  
129

**RECESSED**



Crystal Spotlight  
168-169



Fairy  
170-171



Favilla  
172-173



Fedora  
174-175



Nafir  
176-177



Spillray  
178-179



Nafir  
130-131



Orchid  
132-133



Skin  
134



Skirt  
135



Sol  
136-137

**LARGE SCALE**



Urban  
138-139



Urban Mini  
140-141



Velvet  
142



Voluptas  
143



Anadem  
182-183



Bell  
184-191



Euler  
192-193



Framework LED  
194-197

**TABLE**



Aibu  
146-147



Ax 20  
148-149



Clavius  
150-151



Muse  
152-153



Skirt  
154-155



Layers  
198-199



Melting Pot  
200-203



Plumage  
204-205



Shatter LED  
206-207



Skin  
208-209



Skirt  
210-213



U-light  
214-225



Velvet  
226-227

**FLOOR**



Ax 20  
158-159



Clavius  
160-161



Melting Pot  
162-163



Orchid  
164-165

**BESPOKE**

228





**THE DESIGNERS**

p. 1-3

**SUSPENSION**

p. 4-67

**WALL**

p. 68-99

**WALL & CEILING**

p. 100-117

**CEILING**

p. 118-143

**TABLE**

p. 144-155

**FLOOR**

p. 156-165

**RECESSED**

p. 166-179

**LARGE SCALE**

p. 180-227

**BESPOKE**

p. 228-239



GIOVANNI BARBATO  
MANUEL BORRI/DIAGORA DESIGN  
CAMBI SCATENA TURINI  
SERGE & ROBERT CORNELISSEN  
RYOSUKE FUKUSADA  
DIMA LOGINOFF  
RAINER MUTSCH  
KARIM RASHID  
BRIAN RASMUSSEN  
TIMO RIPATTI  
SANDRO SANTANTONIO  
LORENZO TRUANT  
MANUEL VIVIAN  
VANESSA VIVIAN



**GIOVANNI BARBATO**

Giovanni Barbato was born in Padua in 1974. He attended the University of Architecture in Venice and took an Industrial Design class in Padua. In 2013, he designed the "Spiry" collection for Axo Light, which led him to win a "Good Design Award", one of the most coveted design prizes. In 2015, he designed the "Hoops" and "Aibu" collections for Axo Light.



**MANUEL BORRI  
DIAGORA DESIGN**

Diagora Design studio deals with industrial & interior design, graphics, and project development with a particular focus on the research of innovative materials and the use of new productive technologies. Hidden behind the alias Diagora Design is the designer Manuel Borri, who is supported by a small team of young and dynamic professionals.



**CAMBI SCATENA  
TURINI**

"Cambi, Scatena, Turini Architects" Studio is a design laboratory founded in 1998 with headquarters near Pisa, steps away from the Fortress of Brunelleschi. Since its establishment, the Studio is interested and involved in architecture, urban design, interior and industrial design.



**ROBERT & SERGE  
CORNELISSEN**

The Serge Cornelissen design office was founded by architect Serge Cornelissen in 1993, and specializes exclusively in the design of architectural lighting product. The studio works for several trendsetting lighting companies worldwide. Cornelissen studio designs are regularly awarded at international design awards.



**RYOSUKE FUKUSADA**

Ryosuke Fukusada was born in 1979 in Osaka, Japan. He studied product design at the Kanazawa College of Art. He then worked for Sharp. After transferring to Italy, he graduated from the Domus Academy. In 2008, he worked for Studio Urquiola in Milan. He then started his own studio in 2012 in Kyoto, Japan. He currently works with some international clients



**DIMA LOGINOFF**

Best Designer of The Year (Elle Decoration Best of The Year Award 2014) award winner Dima Loginoff, has already designed 20 collections for world-famous international brands. One of his lamps, Mountain View, designed for Axo Light was awarded twice as Best Lighting in the USA (Best of the Year Award) and in Russia (Elle Decoration Best of The Year Award ).



**TIMO RIPATTI**

Educated as a furniture designer and architect, Timo Ripatti leads Studio Ripatti in Helsinki. He is working mainly in the field of product design with clients across the Europe. His mission is to combine aesthetic, poetic, and functional qualities into his work while achieving a perfect balance with the space and architecture.



**SANDRO SANTANTONIO**

Sandro Santantonio Design handles architecture, interior and industrial design, graphics, packaging and fashion design, while focusing on tendencies research, material study, and new technologies about contract, fashion, and lighting design. Sandro Santantonio publicizes his research by publishing them in major international magazines.



**RAINER MUTSCH**

Rainer Mutsch studied Industrial Design at the University of Applied Arts in Vienna, Furniture Design at the Denmark Design School in Copenhagen and Product Design at the University of Arts in Berlin. He opened his own design studio in Vienna in 2008. His products have received several international design awards, such as the Red Dot Design Award.



**KARIM RASHID**

Karim Rashid is one of the most prolific designers of his generation. Over 4000 designs in production, over 300 awards, and working in over 35 countries attest to Karim's legend of design. His award winning designs include everyday objects, interiors, furniture, brand identity, high-tech products, and luxury goods.



**BRIAN RASMUSSEN**

Brian Rasmussen was born in Ringsted, Denmark in 1973. He graduated from the "Royal Academy of Architecture" in Copenhagen in 2000. In 2004, he won the international "TARGETTI LIGHT ART AWARD", which became the starting point for his career as a lighting designer. Now Brian Rasmussen works with many important design firms.



**LORENZO TRUANT**

Lorenzo Truant graduated in architecture in 2001. After obtaining his degree and a master in Product Design, he worked in the lighting design area. He has worked for over 10 years as an Art Director at Axo Light. He designs light exploring all the possible implications of LED and OLED technology.



**MANUEL VIVIAN**

Born in Venice in 1971, Manuel Vivian obtained his diploma at the Venice Art Institute and began to design at a very young age, focusing on blown glass in particular, thanks also to his family business. Since the creation of Axo Light in 1996, he has collaborated constantly with the company and has become one of the main designers



**VANESSA VIVIAN**

Vanessa Vivian was born in 1994 in Mirano, Venice. From a very young age she showed a keen eye, a strong passion and talent for design, particularly with glass and light. "Layers" and "Plumage" were designed by Vanessa.



suspension

- ALRISHA
- ALYSOID
- AURA
- AX 20
- BELL
- CLAVIUS
- EXPLO
- FAIRY
- FEDORA
- HOOPS
- MELTING POT
- MOUNTAIN VIEW
- MUSE
- NAFIR
- ORCHID
- RYTHMOS
- SKIN
- SKIRT
- SPILLRAY
- SPIRY
- STILLA
- URBAN
- URBAN MINI
- VELVET
- VIRTUS







**ALRISHA**  
design Brian Rasmussen



[for more information see the technical guide at p. 4](#)



SUSPENSION

**ALYSOID**  
design Ryosuke Fukusada



SUSPENSION

for more information see the technical guide at p. 5



**ALYSOID**  
design Ryosuke Fukusada



[for more information see the technical guide at p. 5](#)



**AURA**  
design Manuel Vivian

SUSPENSION



for more information see the technical guide at p. 8



SUSPENSION



**AX 20**  
design Manuel Vivian



for more information see the technical guide at p. 10





SUSPENSION

**BELL**  
design Manuel Vivian



SUSPENSION

[for more information see the technical guide at p. 12](#)



**BELL**  
design Manuel Vivian



**CLAVIUS**  
design Manuel Vivian



[for more information see the technical guide at p. 14](#)



SUSPENSION

SUSPENSION





for more information see the technical guide at p. 20

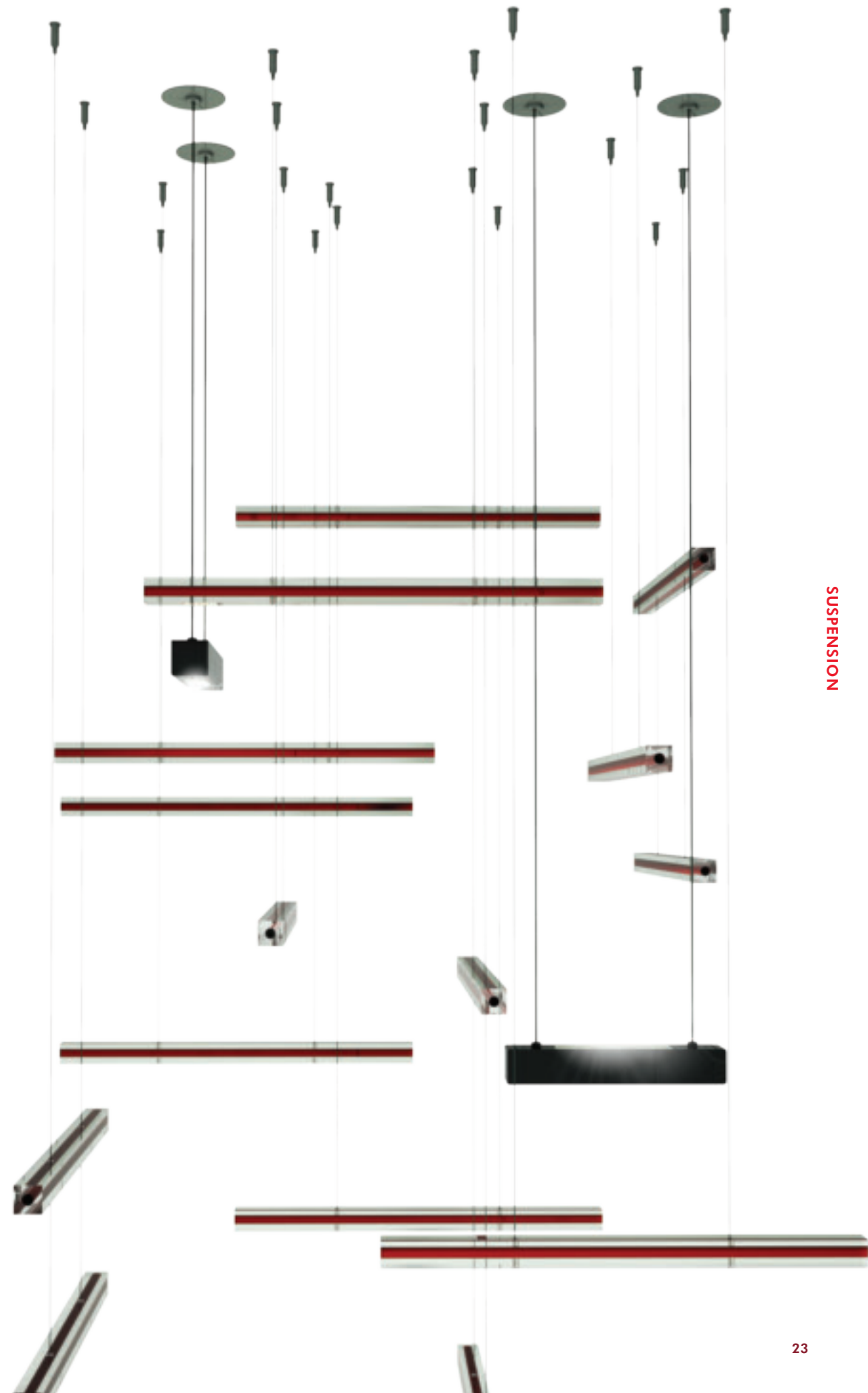

SUSPENSION



**FAIRY**  
design Manuel Vivian



SUSPENSION



for more information see the technical guide at p. 23





**FAIRY**  
design Manuel Vivian

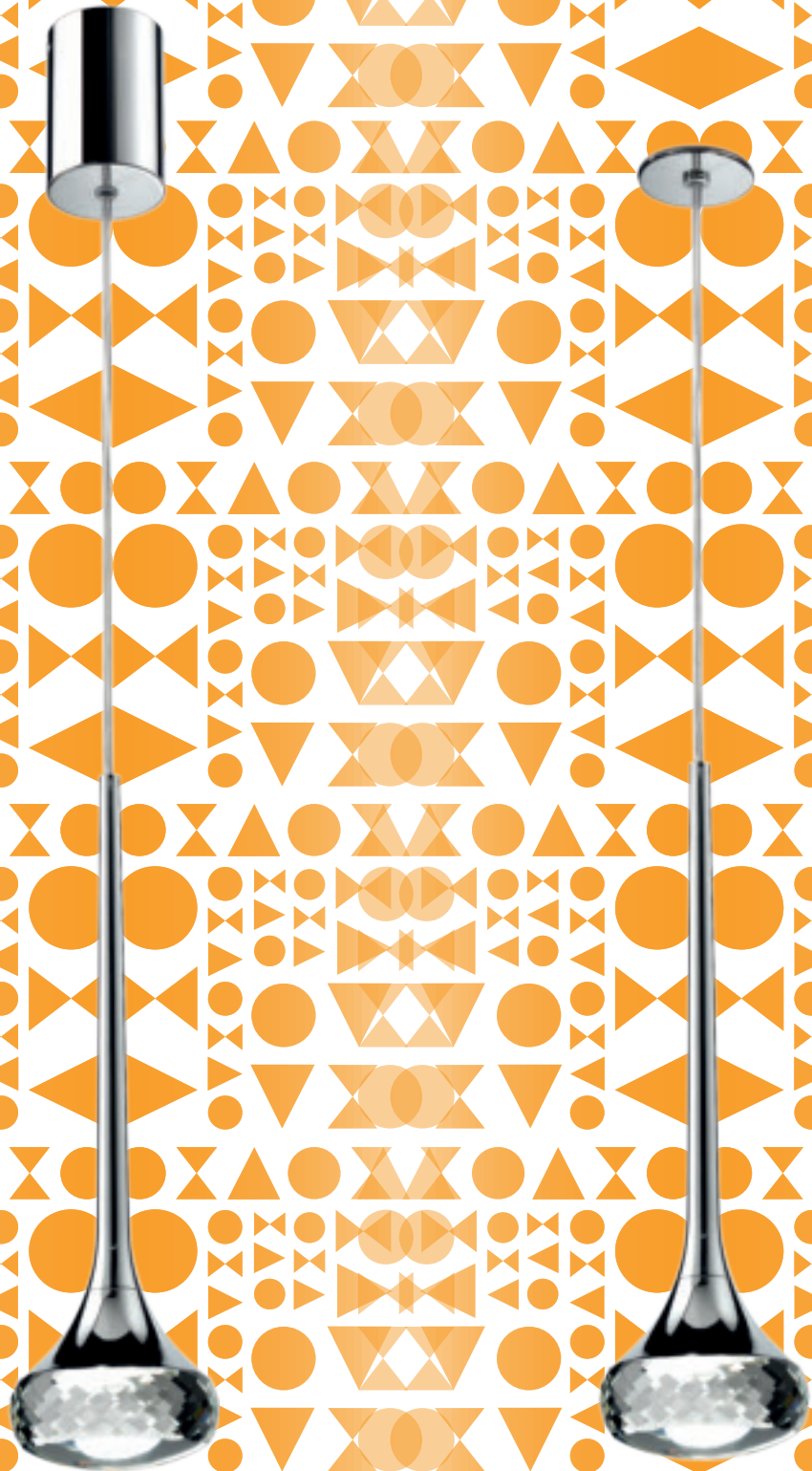

SUSPENSION



SUSPENSION

[for more information see the technical guide at p. 23](#)

**FEDORA**  
design Dima Loginoff



SUSPENSION

for more information see the technical guide at p. 26

**HOOPS**  
design Giovanni Barbato



SUSPENSION



SUSPENSION

for more information see the technical guide at p. 30





**MELTING POT**  
design Sandro Santantonio



for more information see the technical guide at p. 34

**MOUNTAIN VIEW**  
design Dima Loginoff

SUSPENSION



SUSPENSION

[for more information see the technical guide at p. 38](#)





**MUSE**

design Sandro Santantonio



SUSPENSION

[for more information see the technical guide at p. 41](#)



**NAFIR**  
design Karim Rashid

SUSPENSION



SUSPENSION



[for more information see the technical guide at p. 42](#)



**ORCHID**  
design Rainer Mutsch



SUSPENSION

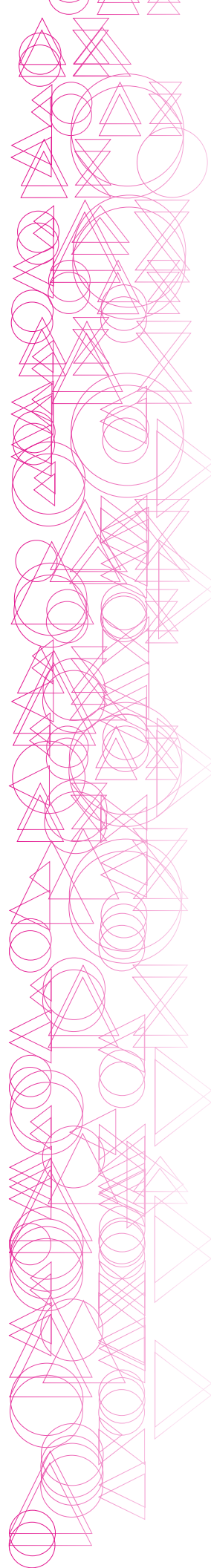

SUSPENSION

for more information see the technical guide at p. 45



**ORCHID**  
design Rainer Mutsch



[for more information see the technical guide at p. 45](#)

**ORCHID**  
design Rainer Mutsch



SUSPENSION



[for more information see the technical guide at p. 45](#)





**RYTHMOS**  
design Serge & Robert Cornelissen



SUSPENSION

for more information see the technical guide at p. 49



**SKIN**  
design Manuel Vivian



for more information see the technical guide at p. 52



**SKIRT**  
design Manuel Vivian

SUSPENSION



[for more information see the technical guide at p. 54](#)



**SKIRT**  
design Manuel Vivian



SUSPENSION

[for more information see the technical guide at p. 54](#)



**SPILLRAY**  
design Manuel Vivian



SUSPENSION

for more information see the technical guide at p. 58



SUSPENSION

**SPILLRAY**  
design Manuel Vivian



SUSPENSION



for more information see the technical guide at p. 58



SUSPENSION



**SPIRY**  
design Giovanni Barbato



SUSPENSION

for more information see the technical guide at p. 63

**STILLA**  
design Manuel Vivian



SUSPENSION

for more information see the technical guide at p. 63

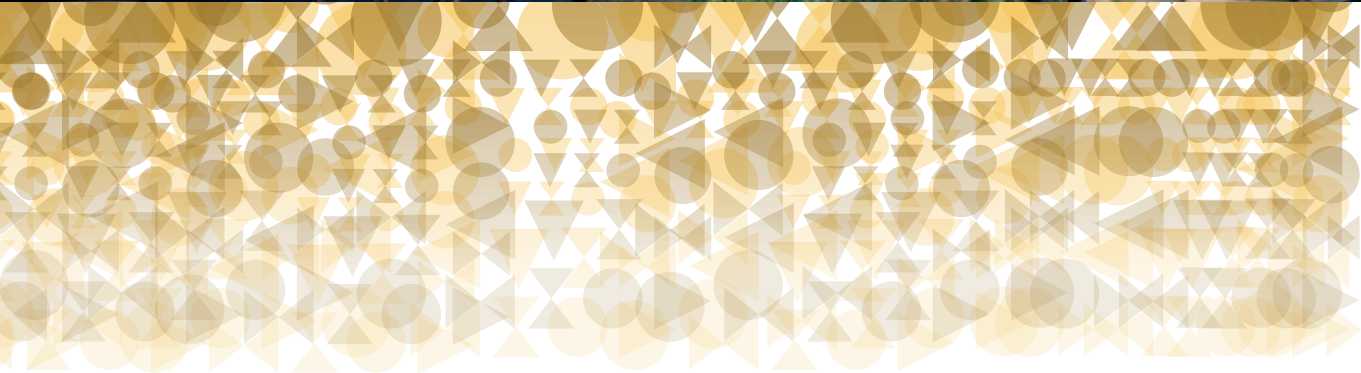

**URBAN**  
design Dima Loginoff

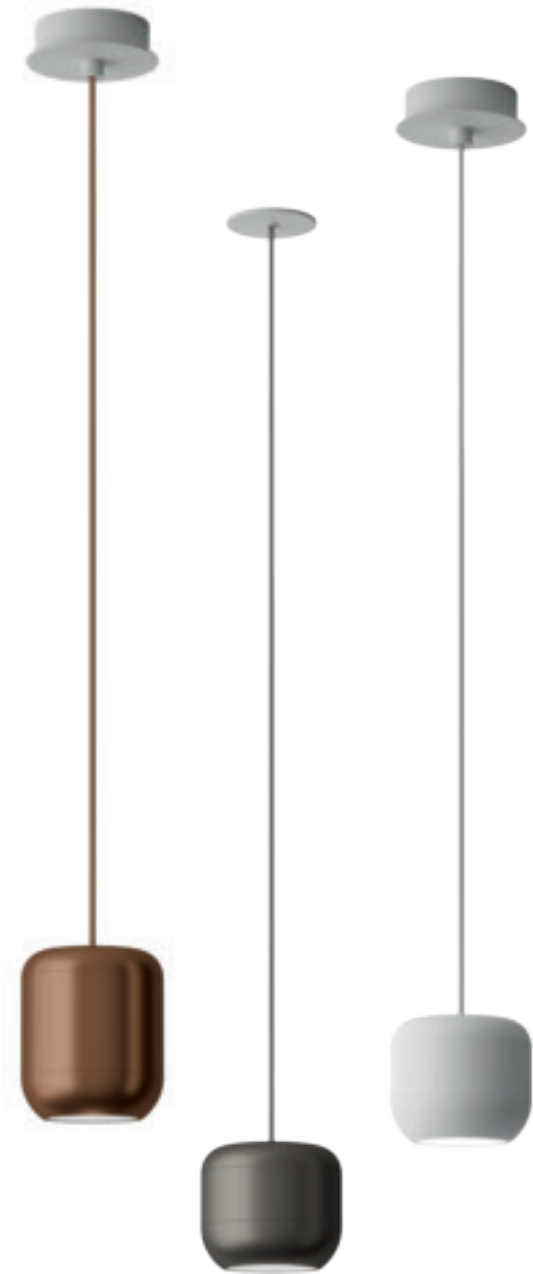

[for more information see the technical guide at p. 70](#)



**URBAN MINI**  
design Dima Loginoff

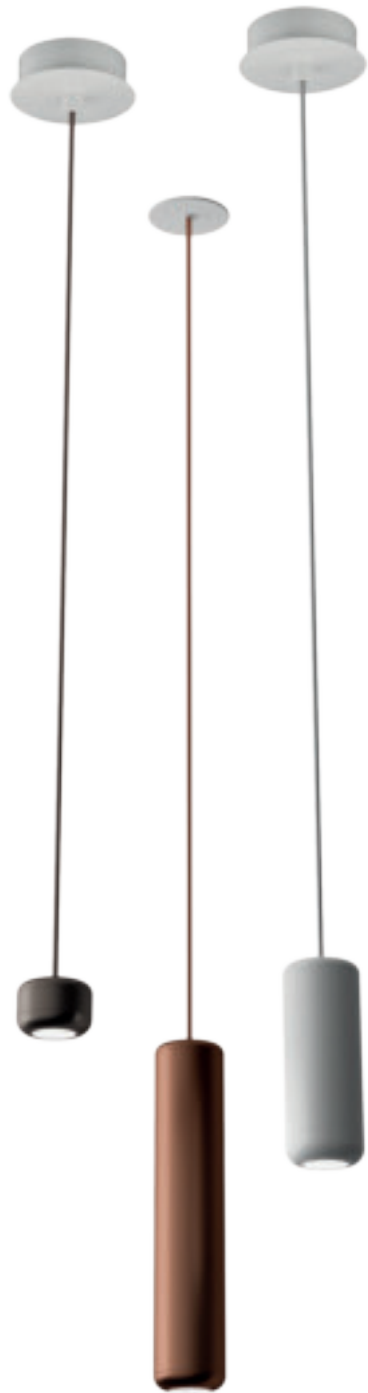

SUSPENSION

[for more information see the technical guide at p. 72](#)



**VELVET**  
design Manuel Vivian



[for more information see the technical guide at p. 76](#)



**VIRTUS**  
design Manuel Vivian



SUSPENSION

for more information see the technical guide at p. 77



SUSPENSION

wall

- ALRISHA
- AURA
- AX 20
- CLAVIUS
- FAIRY
- LIK
- MELTING POT
- MOMUS MINI
- ORCHID
- POLIA LED
- RYTHMOS
- SHATTER LED
- SKIRT
- SPILLRAY
- U-LIGHT
- URIEL
- VASILY
- VOLUPTAS





**ALRISHA**  
design Brian Rasmussen



WALL

[for more information see the technical guide at p. 4](#)

**AURA**  
design Manuel Vivian



[for more information see the technical guide at p. 7](#)



WALL

WALL



[for more information see the technical guide at p. 10](#)



**CLAVIUS**  
design Manuel Vivian



WALL

WALL

[for more information see the technical guide at p. 13](#)



**FAIRY**  
design Manuel Vivian



for more information see the technical guide at p. 22



**LIK**  
design Serge & Robert Cornelissen



for more information see the technical guide at p. 34

WALL

**MELTING POT**  
design Sandro Santantonio

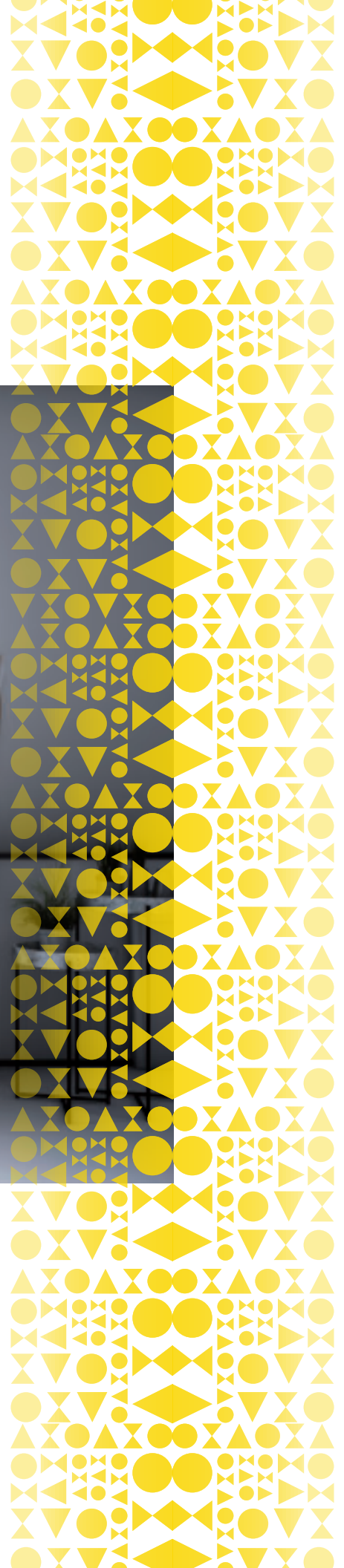

WALL

[for more information see the technical guide at p. 34](#)



**MOMUS MINI**  
design Manuel Vivian

WALL



[for more information see the technical guide at p. 38](#)

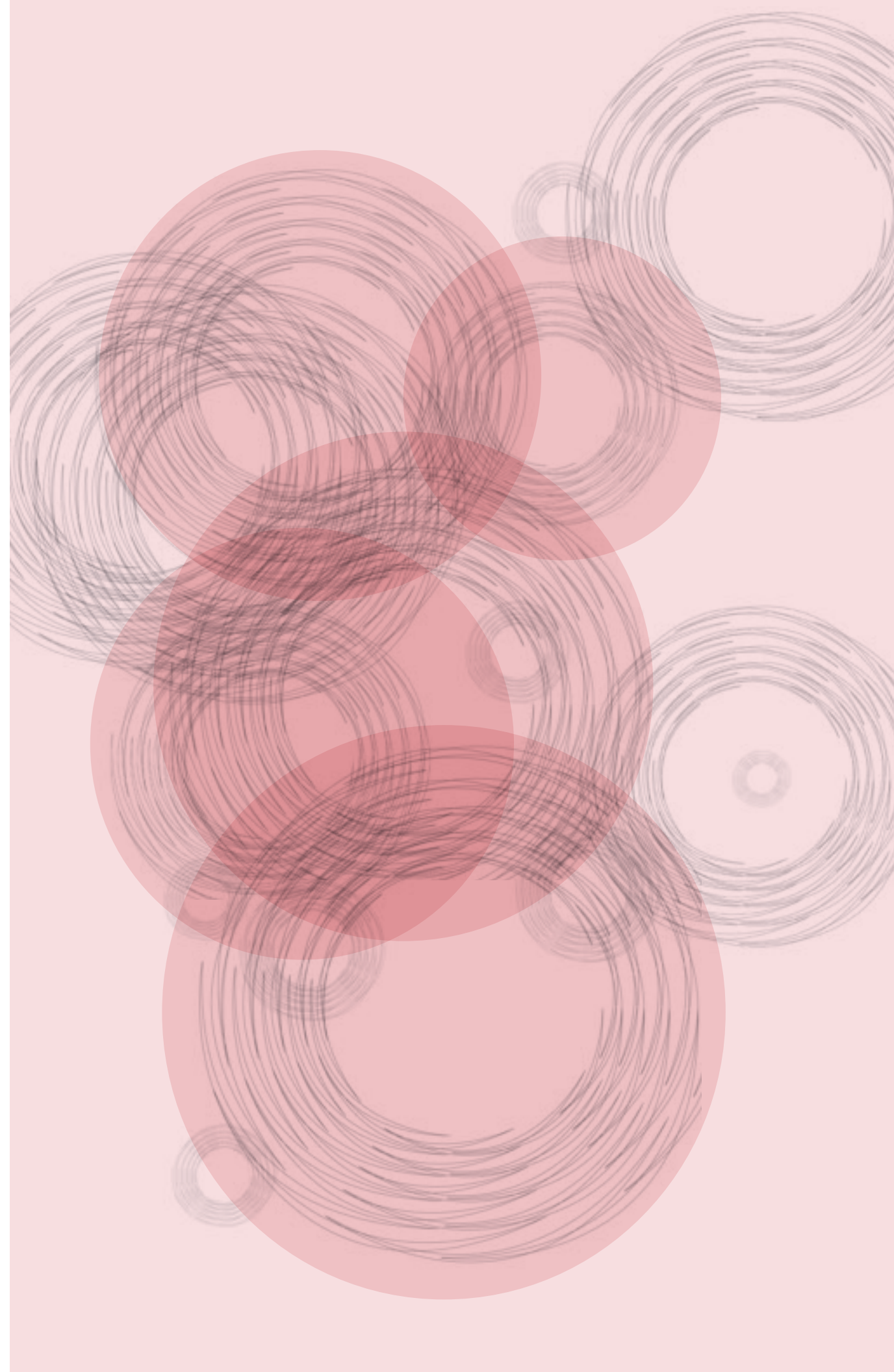

**ORCHID**  
design Rainer Mutsch



WALL

WALL

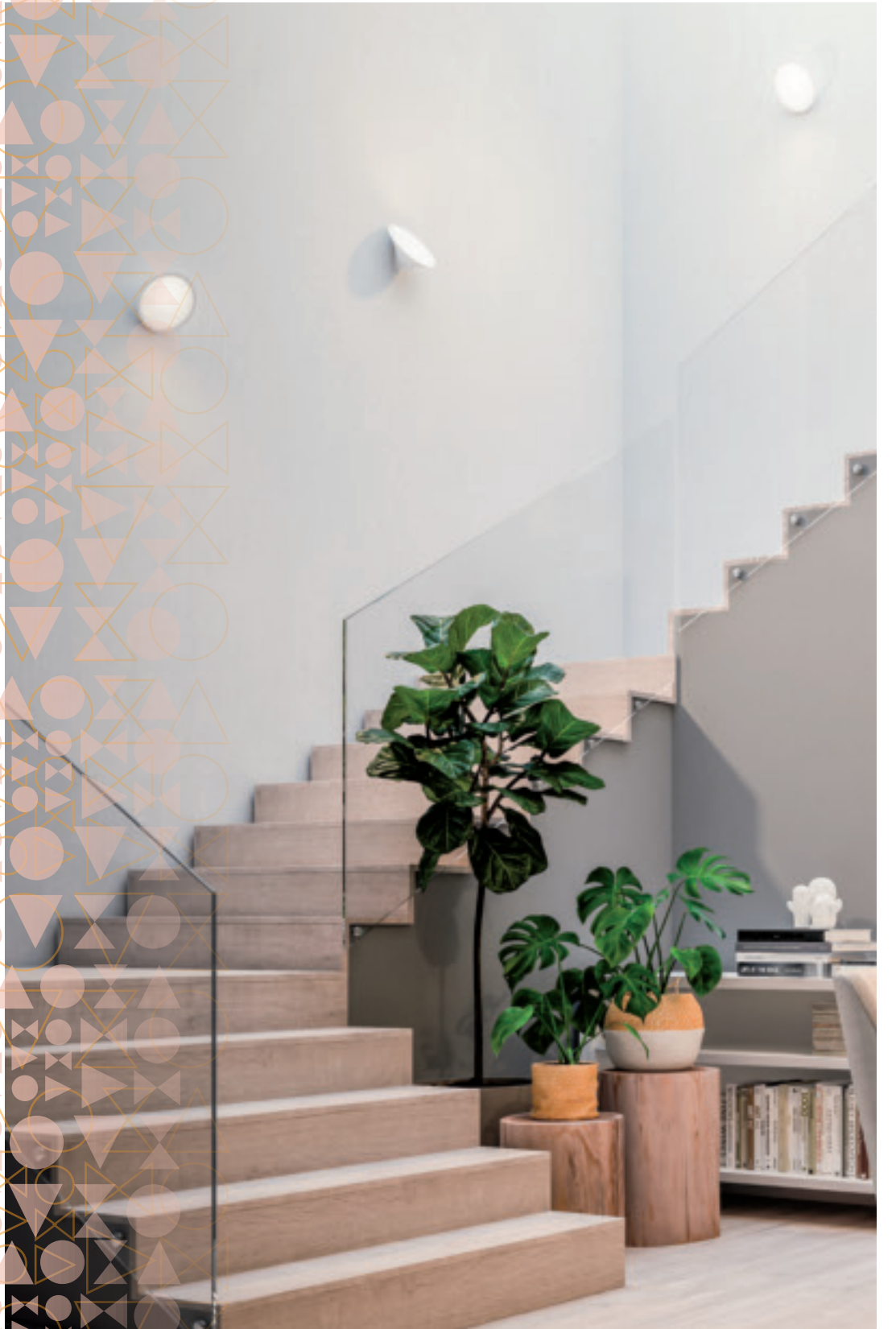

[for more information see the technical guide at p. 44](#)



**POLIA LED**  
design Manuel Vivian



WALL

[for more information see the technical guide at p. 48](#)

**RYTHMOS**

design Serge & Robert Cornelissen

WALL



[for more information see the technical guide at p. 48](#)

**SHATTER LED**

design Serge & Robert Cornelissen

WALL



[for more information see the technical guide at p. 49](#)



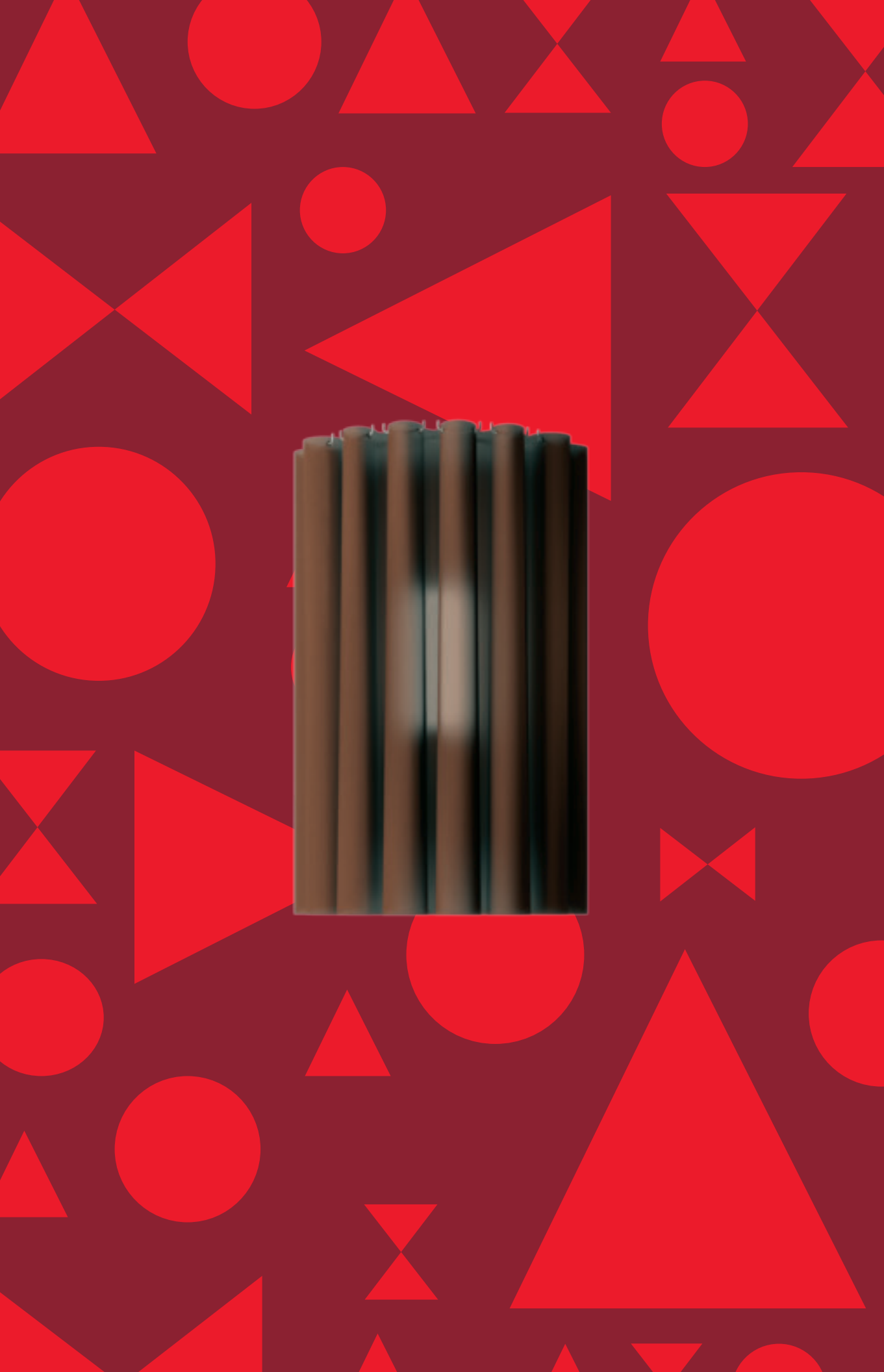

**SKIRT**  
design Manuel Vivian



WALL

[for more information see the technical guide at p. 53](#)

**SPILLRAY**  
design Manuel Vivian



WALL



WALL

[for more information see the technical guide at p. 57](#)





**U-LIGHT**  
design Timo Ripatti



[for more information see the technical guide at p. 65](#)



**URIEL**  
design Manuel Vivian



WALL

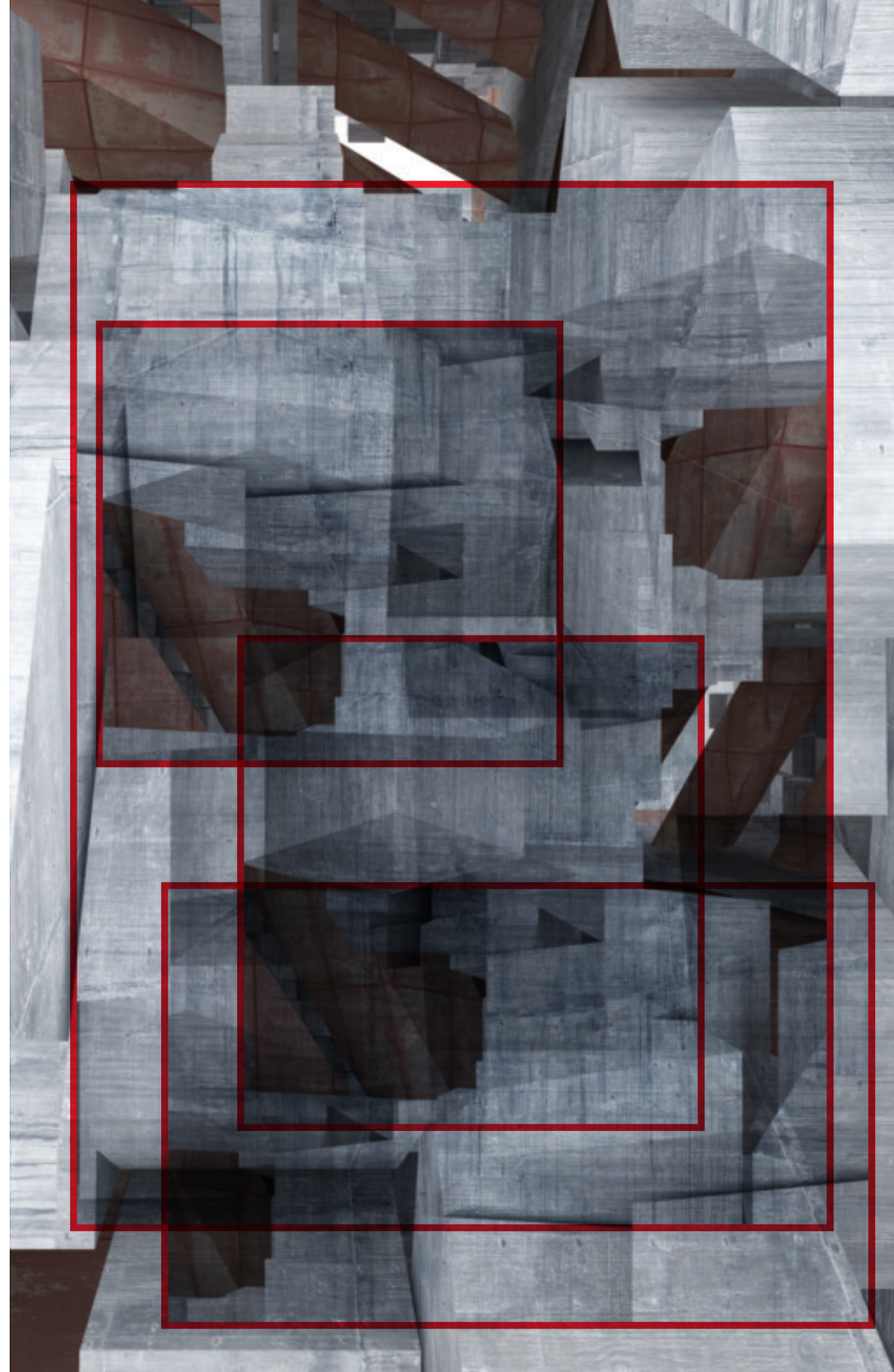

for more information see the technical guide at p. 74



**VASILY**  
design Manuel Vivian



for more information see the technical guide at p. 74

WALL

**VOLUPTAS**  
design Lorenzo Truant

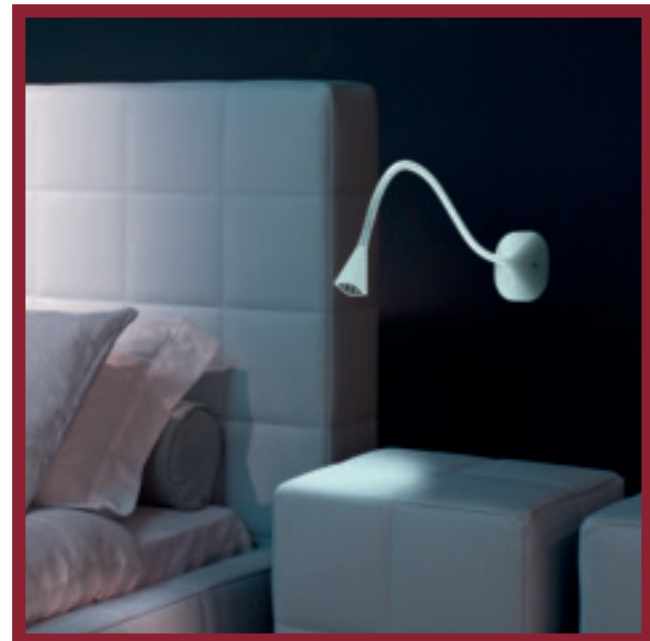

for more information see the technical guide at p. 78

WALL

wall/ceiling

- AX 20
- FAVILLA
- MUSE
- NECKY
- NELLY
- NELLY STRAIGHT
- ORCHID
- STORMY
- UKIYO





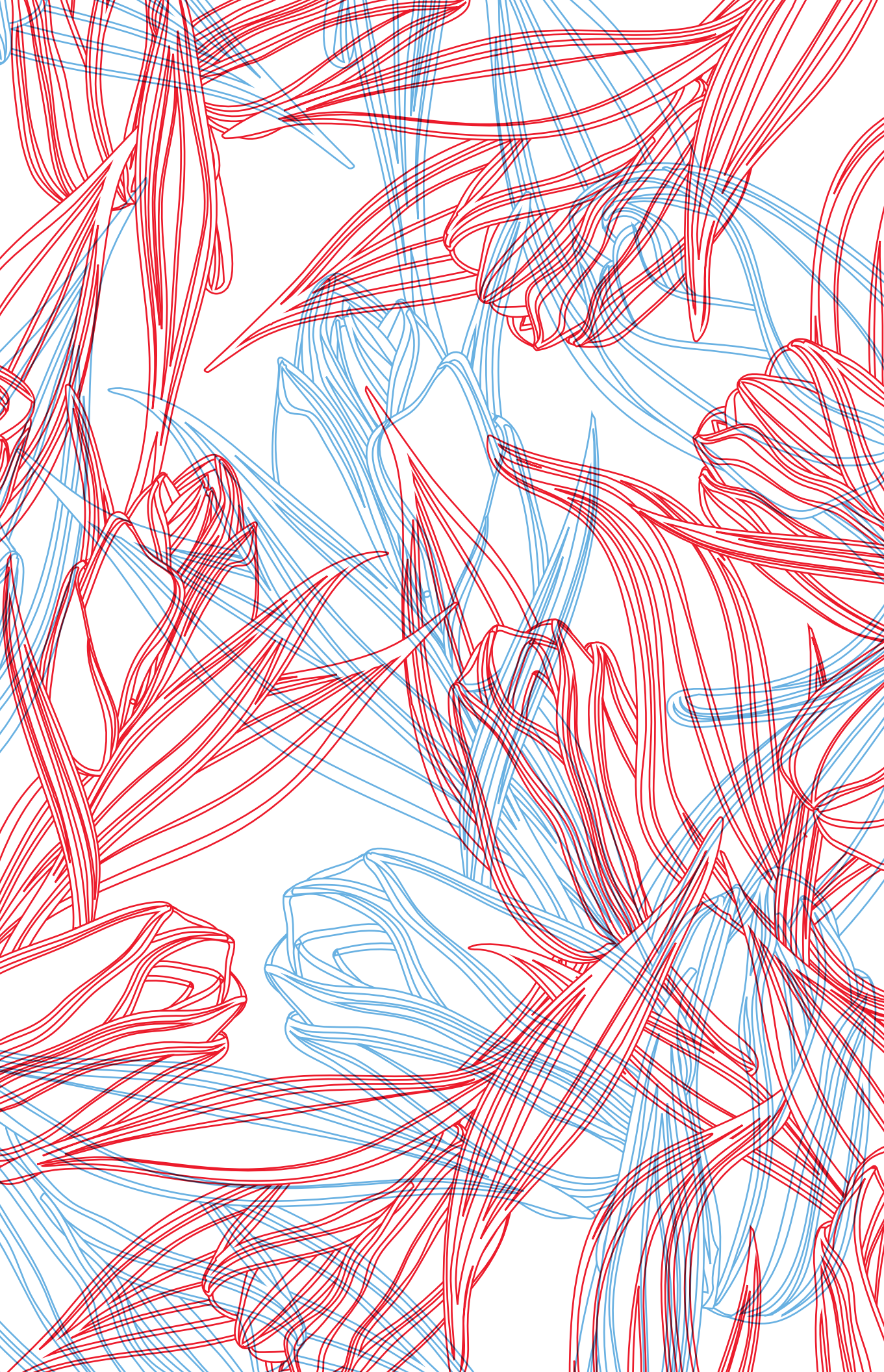

WALL/CEILING





WALL/CEILING

WALL/CEILING



**MUSE**  
design Sandro Santantonio



WALL/CEILING

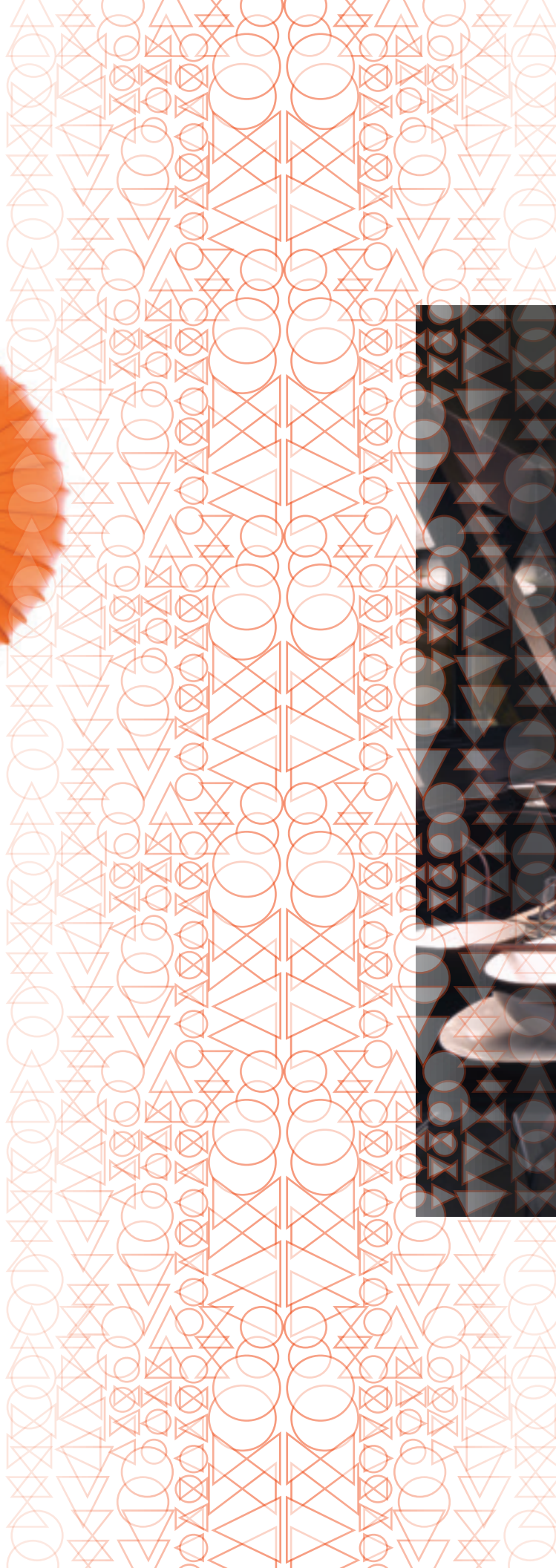

WALL/CEILING

for more information see the technical guide at p. 39



**NECKY**  
design Diagora Design

WALL/CEILING

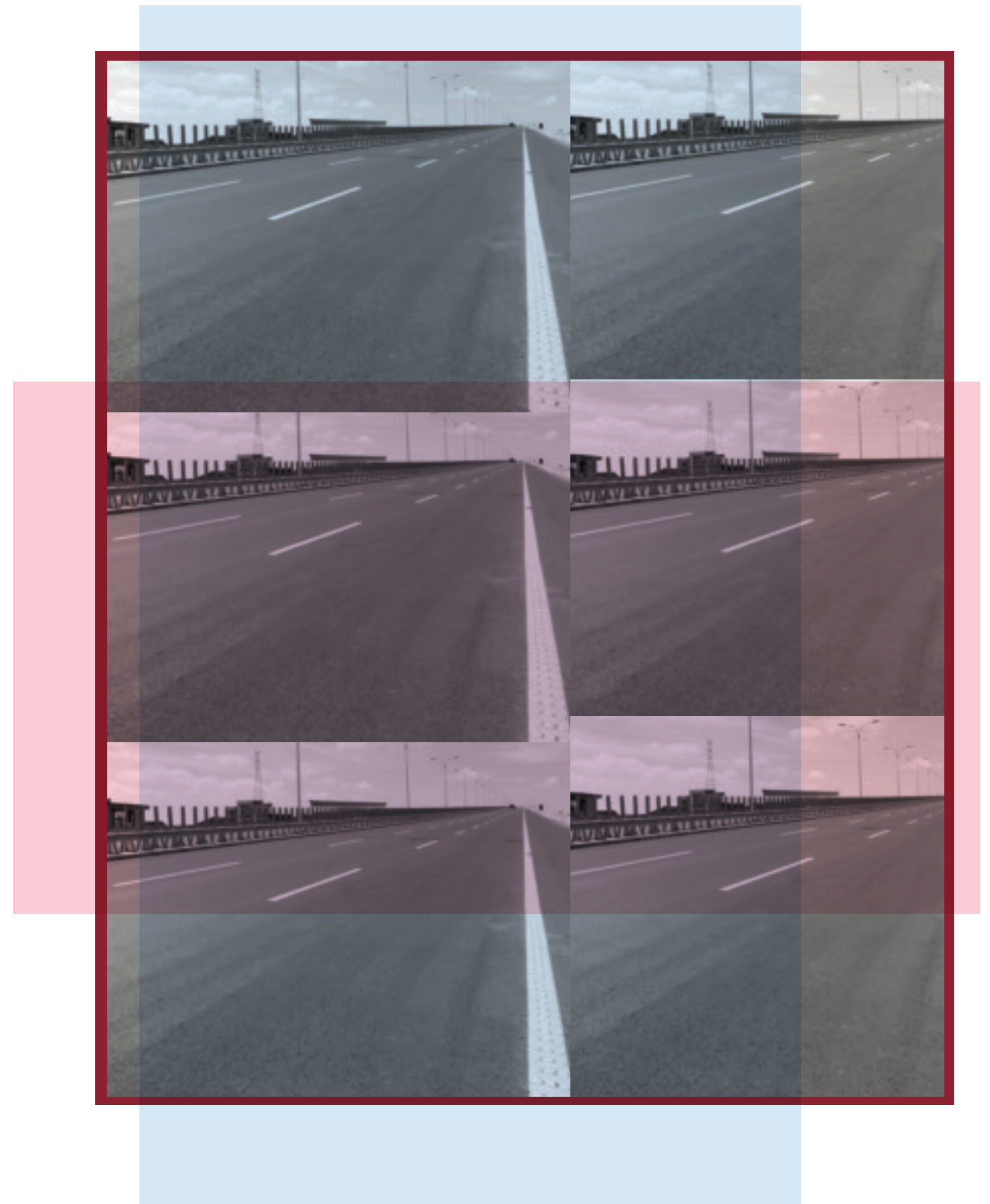

[for more information see the technical guide at p. 43](#)



**NELLY**  
design Manuel Vivian



WALL/CEILING

for more information see the technical guide at p. 43

**NELLY STRAIGHT**  
design Manuel Vivian



WALL/CEILING

for more information see the technical guide at p. 44

**ORCHID**  
design Rainer Mutsch



WALL/CEILING

for more information see the technical guide at p. 44



**STORMY**  
design Manuel Vivian

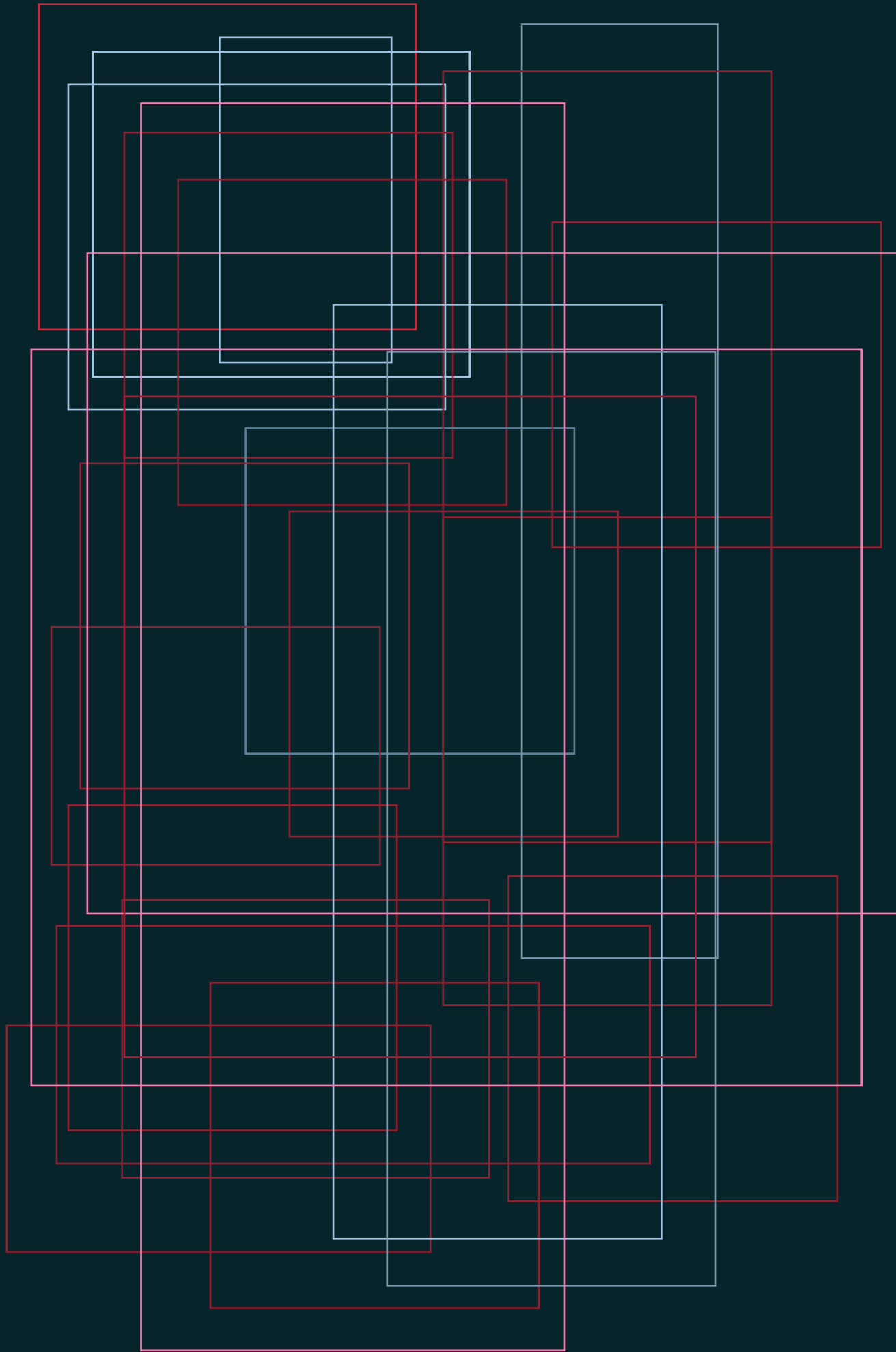

for more information see the technical guide at p. 64

**UKIYO**  
design Manuel Vivian

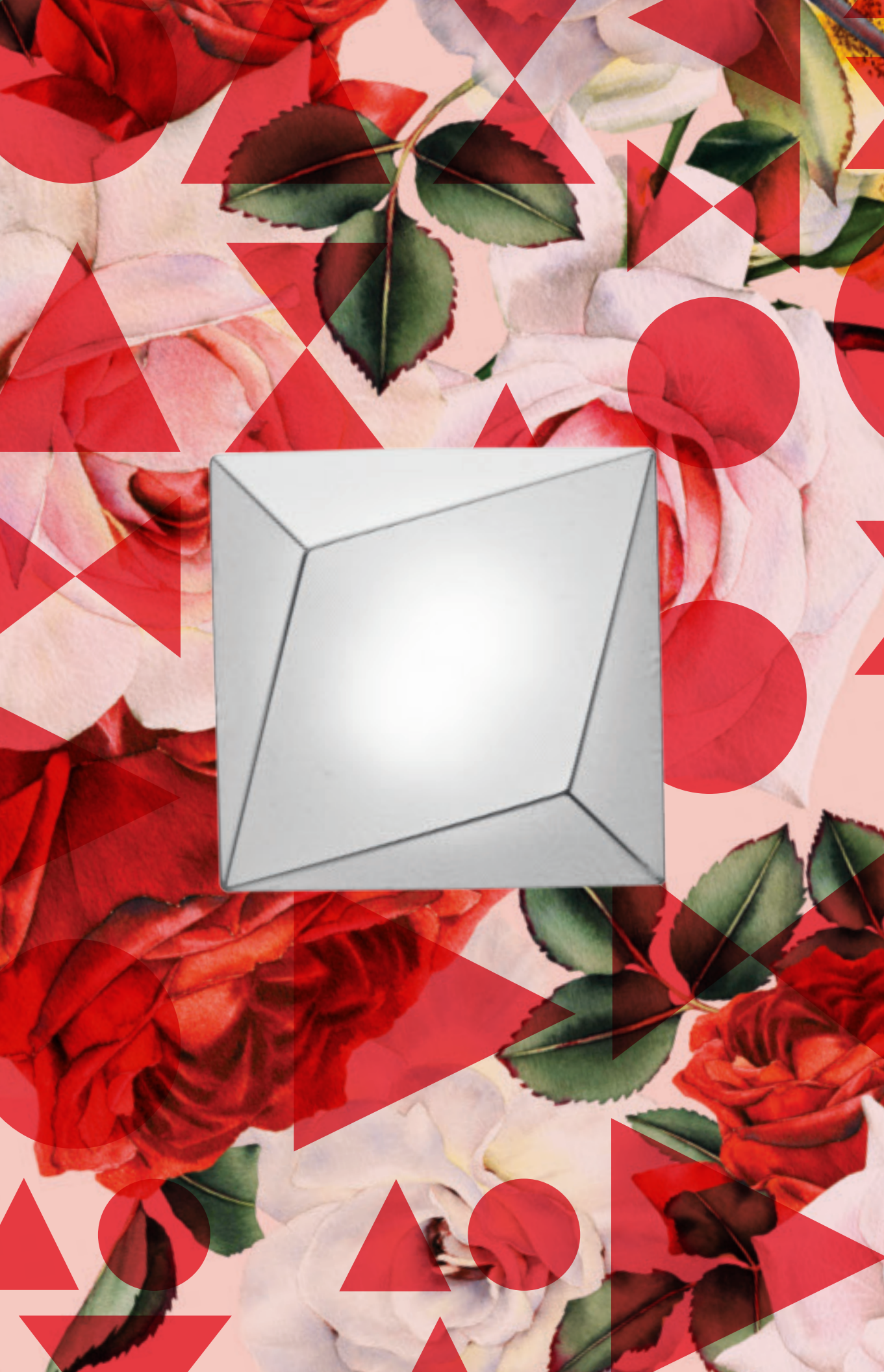

WALL/CEILING

for more information see the technical guide at p. 69



ceiling

- AURA
- BELL
- CLAVIUS
- FAIRY
- HOOPS
- NAFIR
- ORCHID
- SKIN
- SKIRT
- SOL
- URBAN
- URBAN MINI
- VELVET
- VOLUPTAS

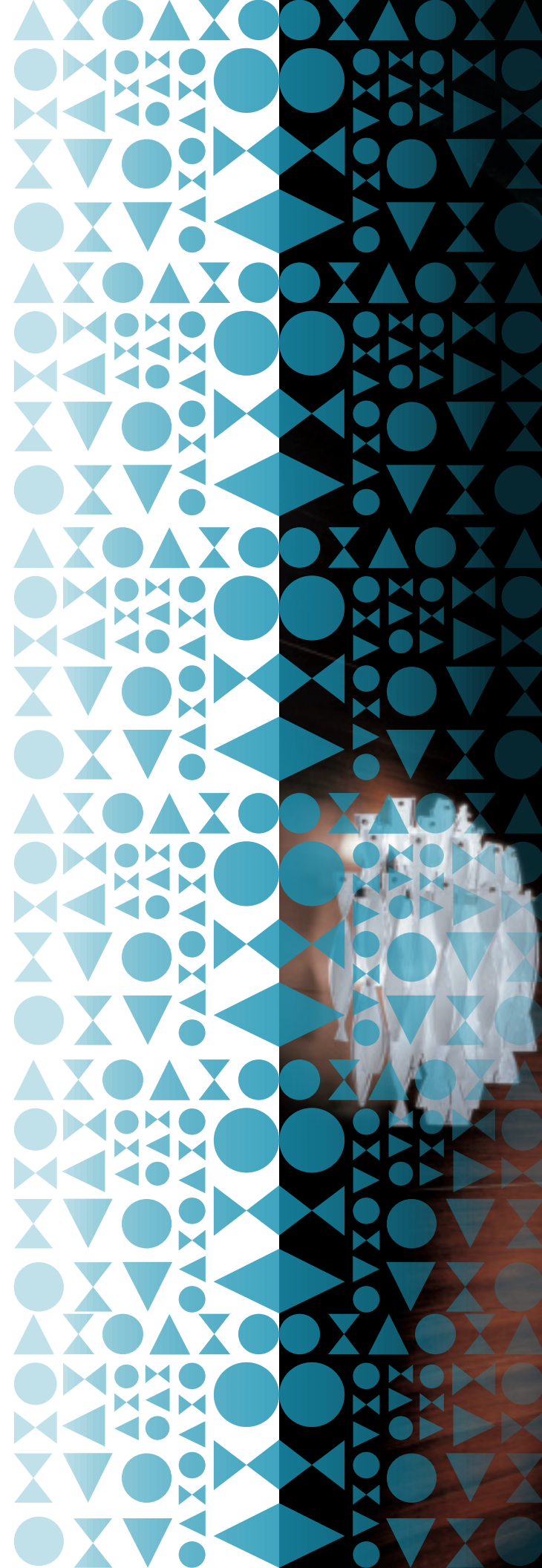

**AURA**  
design Manuel Vivian

CEILING



CEILING







**BELL**  
design Manuel Vivian



for more information see the technical guide at p. 11



CEILING



CEILING



**FAIRY**  
design Manuel Vivian



for more information see the technical guide at p. 22

**HOOPS**  
design Giovanni Barbato

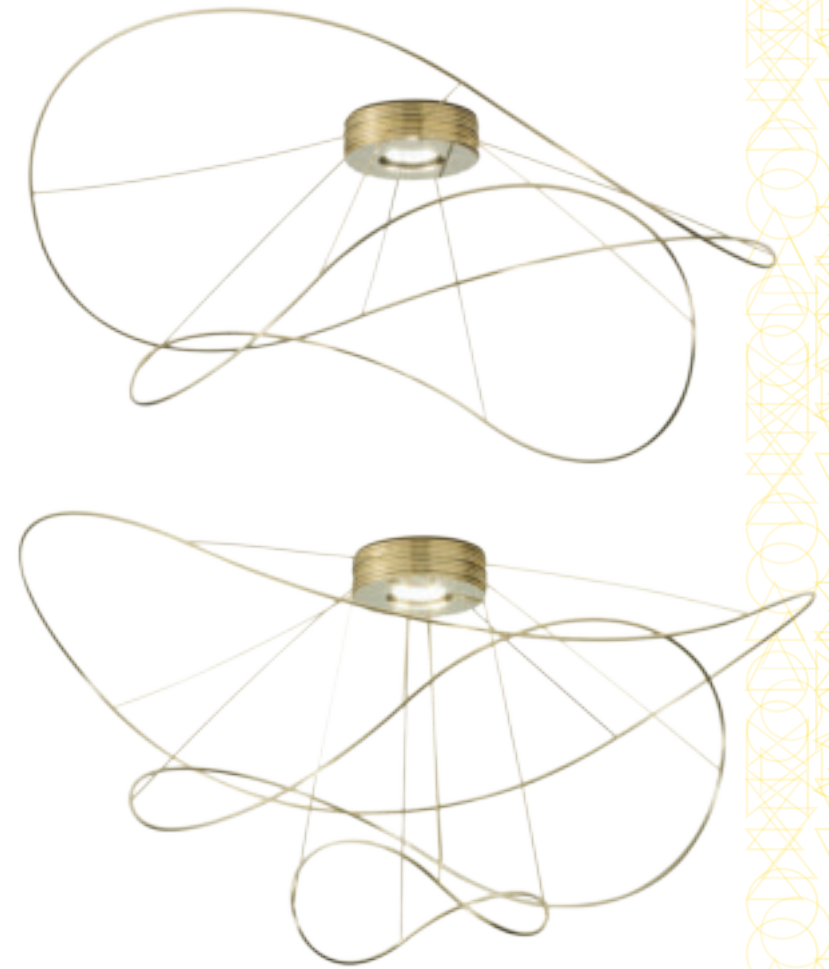

for more information see the technical guide at p. 30





**NAFIR**  
design Karim Rashid





**ORCHID**  
design Rainer Mutsch

CEILING

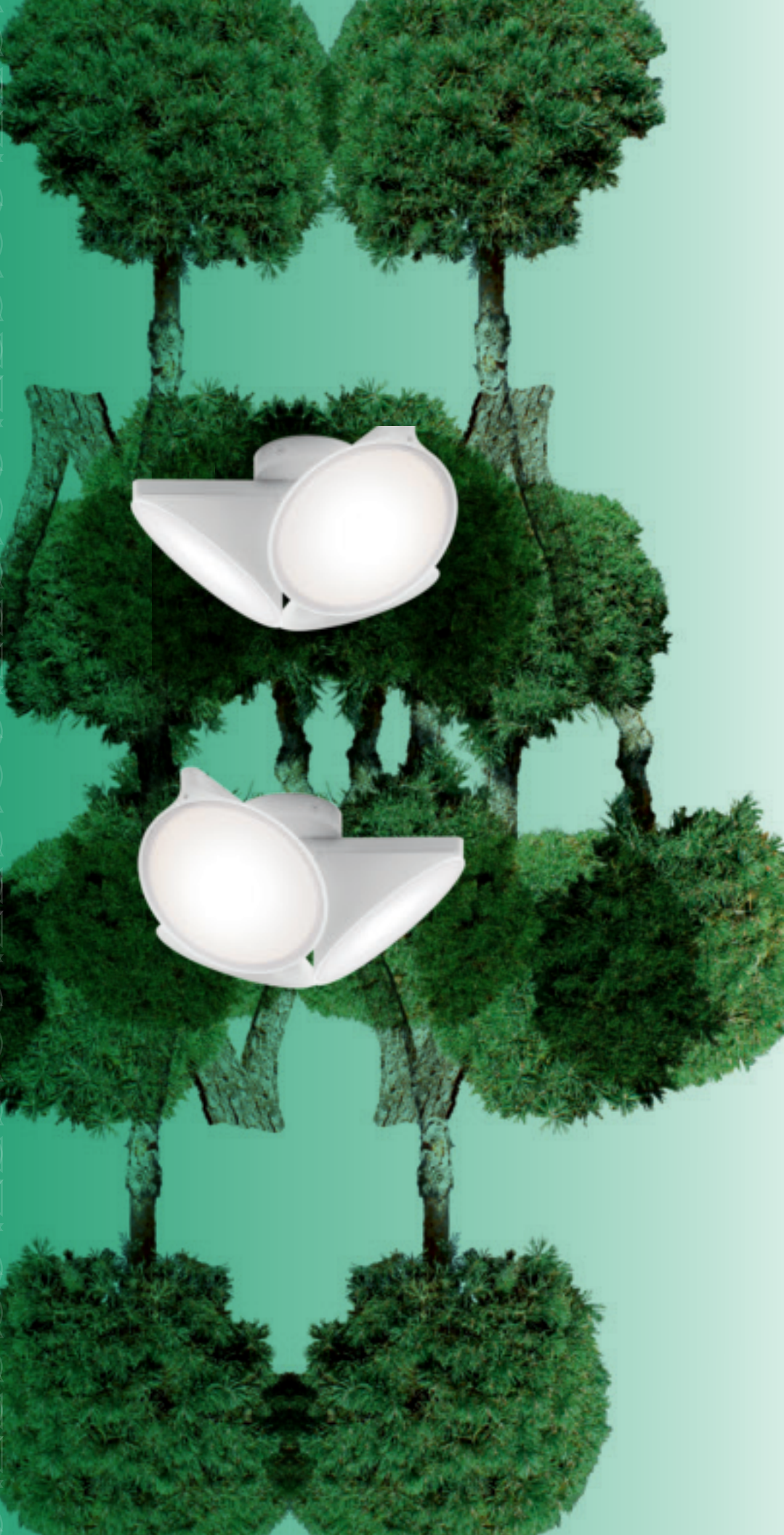

for more information see the technical guide at p. 45



**SKIN**  
design Manuel Vivian



CEILING

**SKIRT**  
design Manuel Vivian

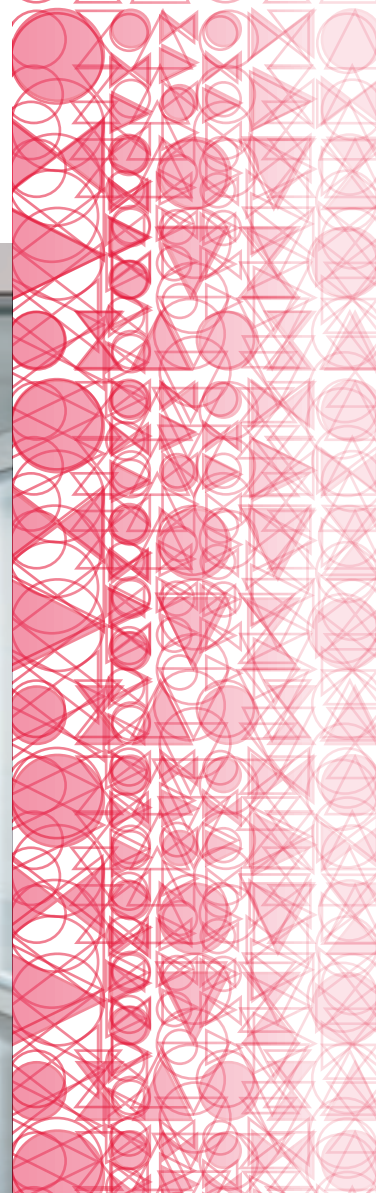

CEILING



for more information see the technical guide at p. 51

for more information see the technical guide at p. 53

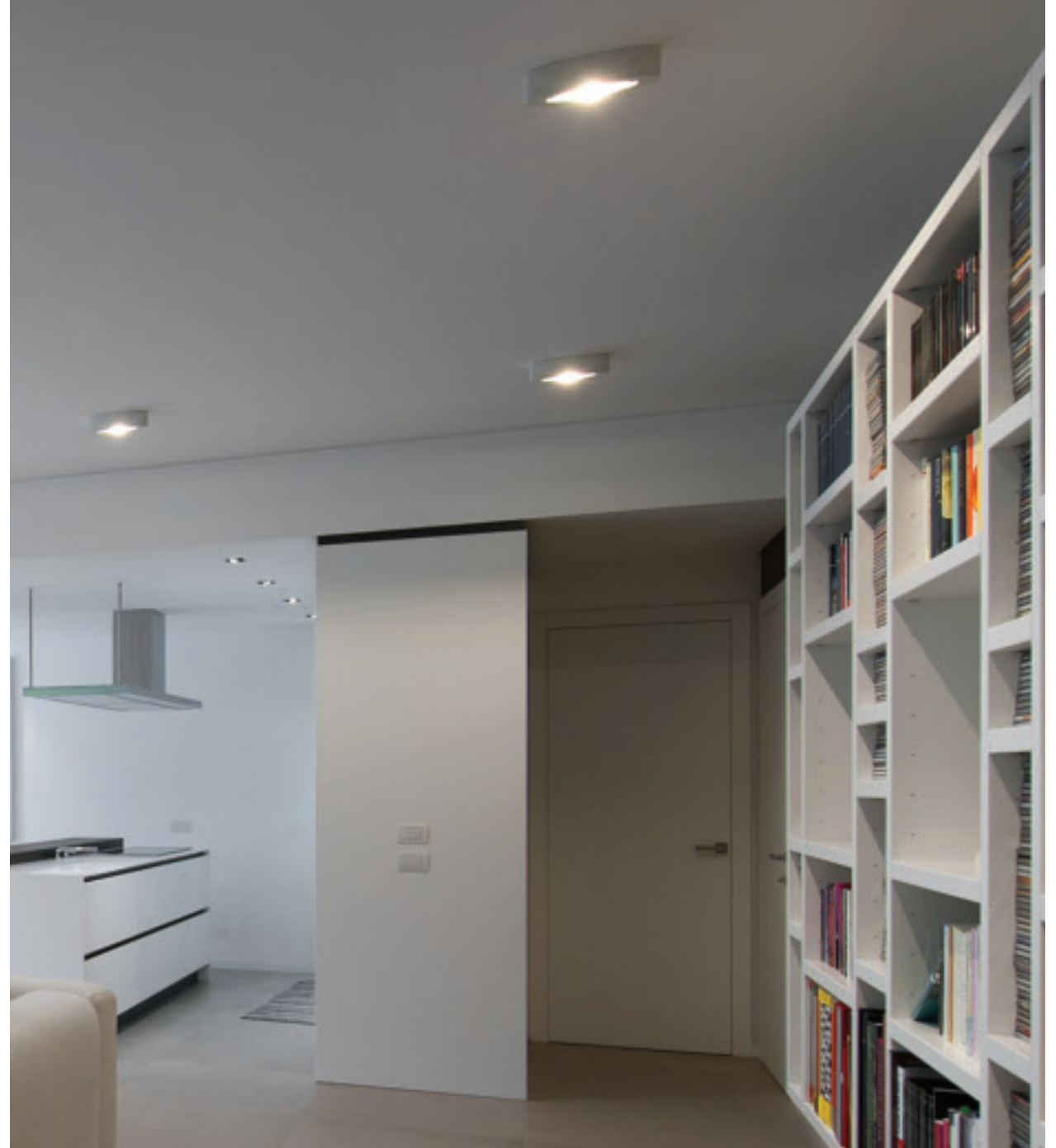



**URBAN**  
design Dima Loginoff

CEILING



[for more information see the technical guide at p. 70](#)

**URBAN MINI**  
design Dima Loginoff

CEILING



[for more information see the technical guide at p. 72](#)

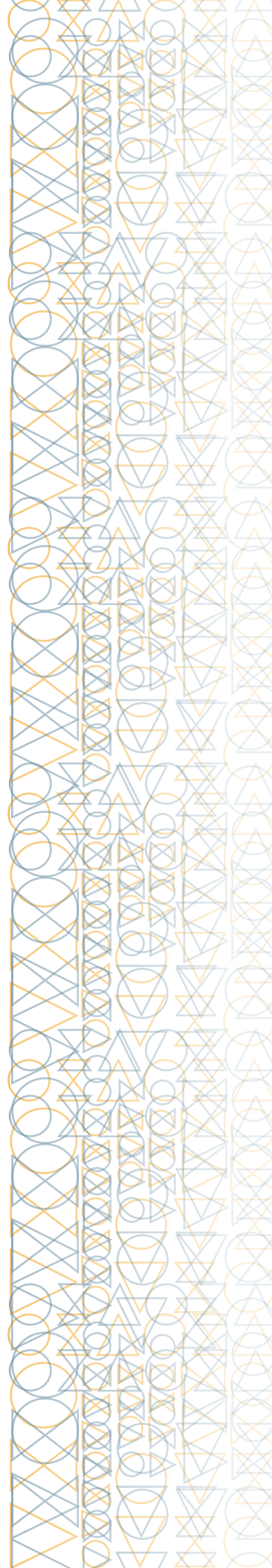

CEILING



**VELVET**  
design Manuel Vivian



CEILING

[for more information see the technical guide at p. 75](#)

**VOLUPTAS**  
design Lorenzo Truant

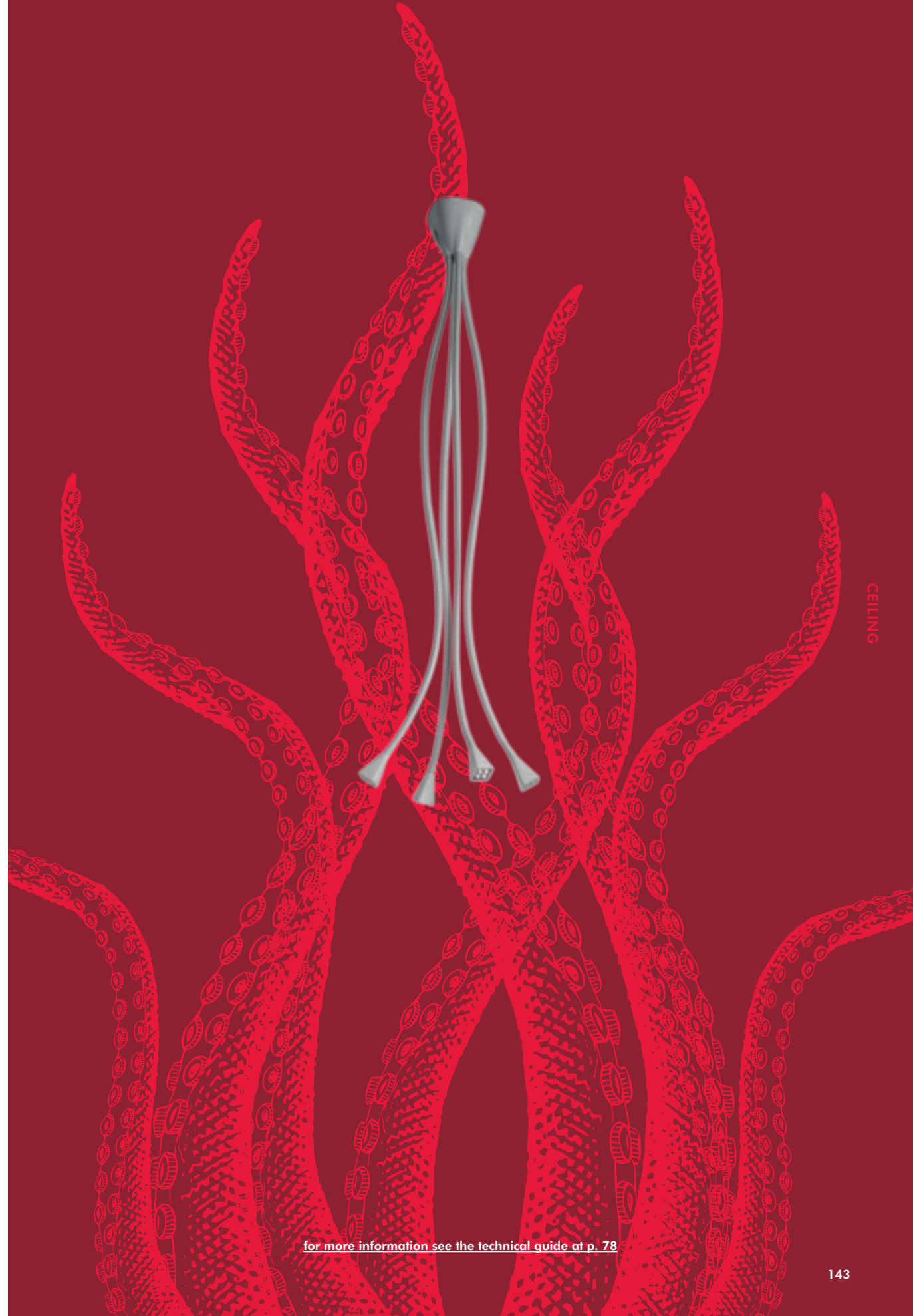

CEILING

[for more information see the technical guide at p. 78](#)

table

AIBU  
AX 20  
CLAVIUS  
MUSE  
SKIRT





**AIBU**  
design Giovanni Barbato



[for more information see the technical guide at p. 4](#)

TABLE



**AX 20**  
design Manuel Vivian



TABLE

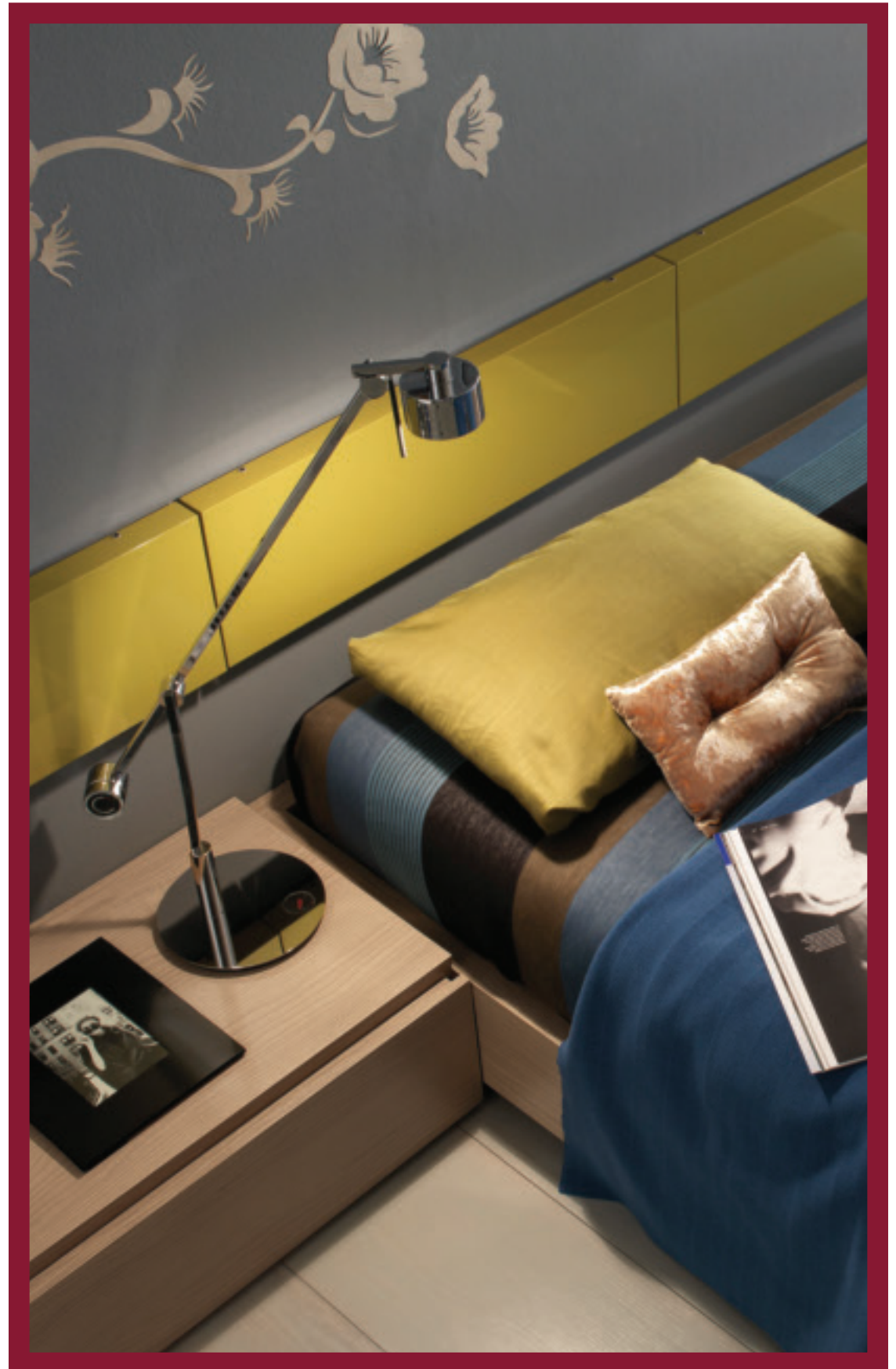

TABLE

[for more information see the technical guide at p. 10](#)





**CLAVIUS**  
design Manuel Vivian



TABLE

for more information see the technical guide at p. 17

**MUSE**  
design Sandro Santantonio

TABLE



[for more information see the technical guide at p. 41](#)

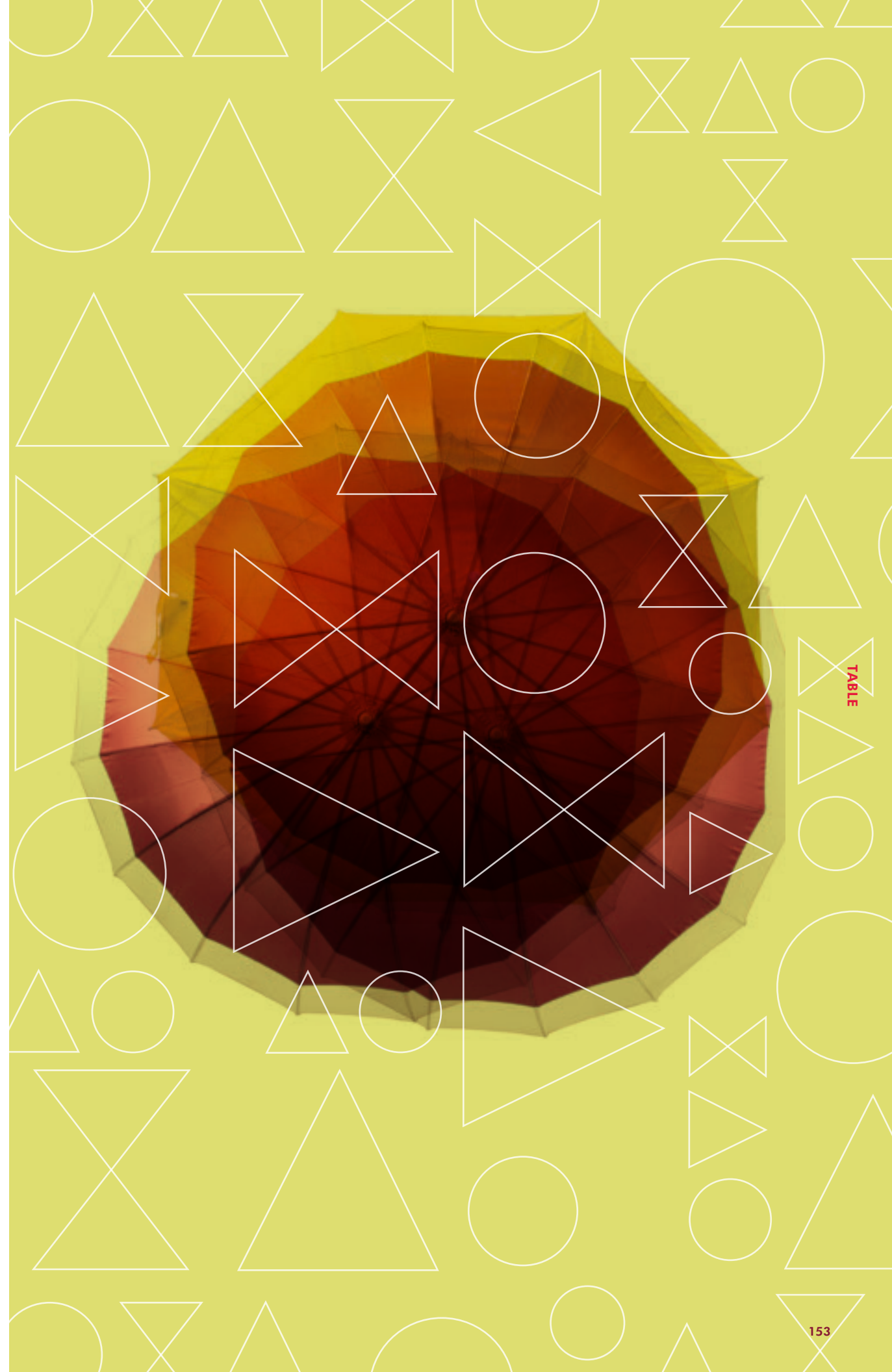

TABLE



**SKIRT**  
design Manuel Vivian

TABLE



[for more information see the technical guide at p. 57](#)



floor

AX 20  
CLAVIUS  
MELTING POT  
ORCHID





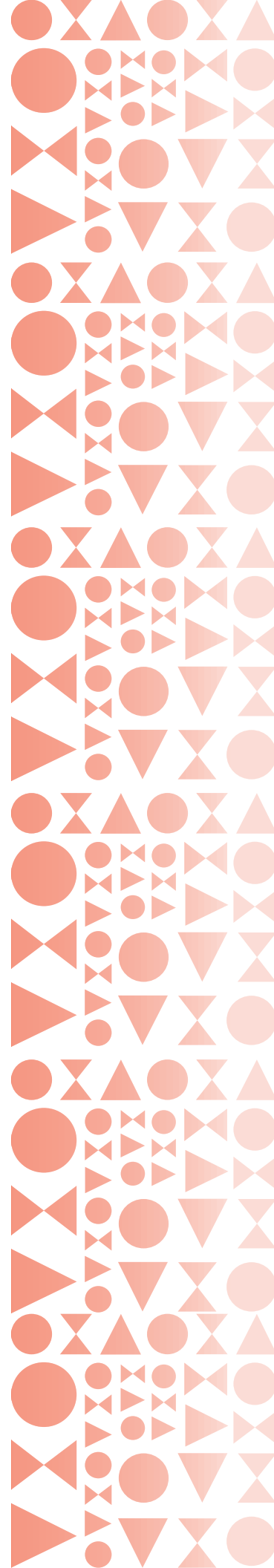

**AX 20**  
design Manuel Vivian



[for more information see the technical guide at p. 10](#)

FLOOR



**CLAVIUS**  
design Manuel Vivian



FLOOR

[for more information see the technical guide at p. 17](#)



**MELTING POT**  
design Sandro Santantonio



FLOOR

FLOOR



[for more information see the technical guide at p. 37](#)

**ORCHID**  
design Rainer Mutsch



FLOOR

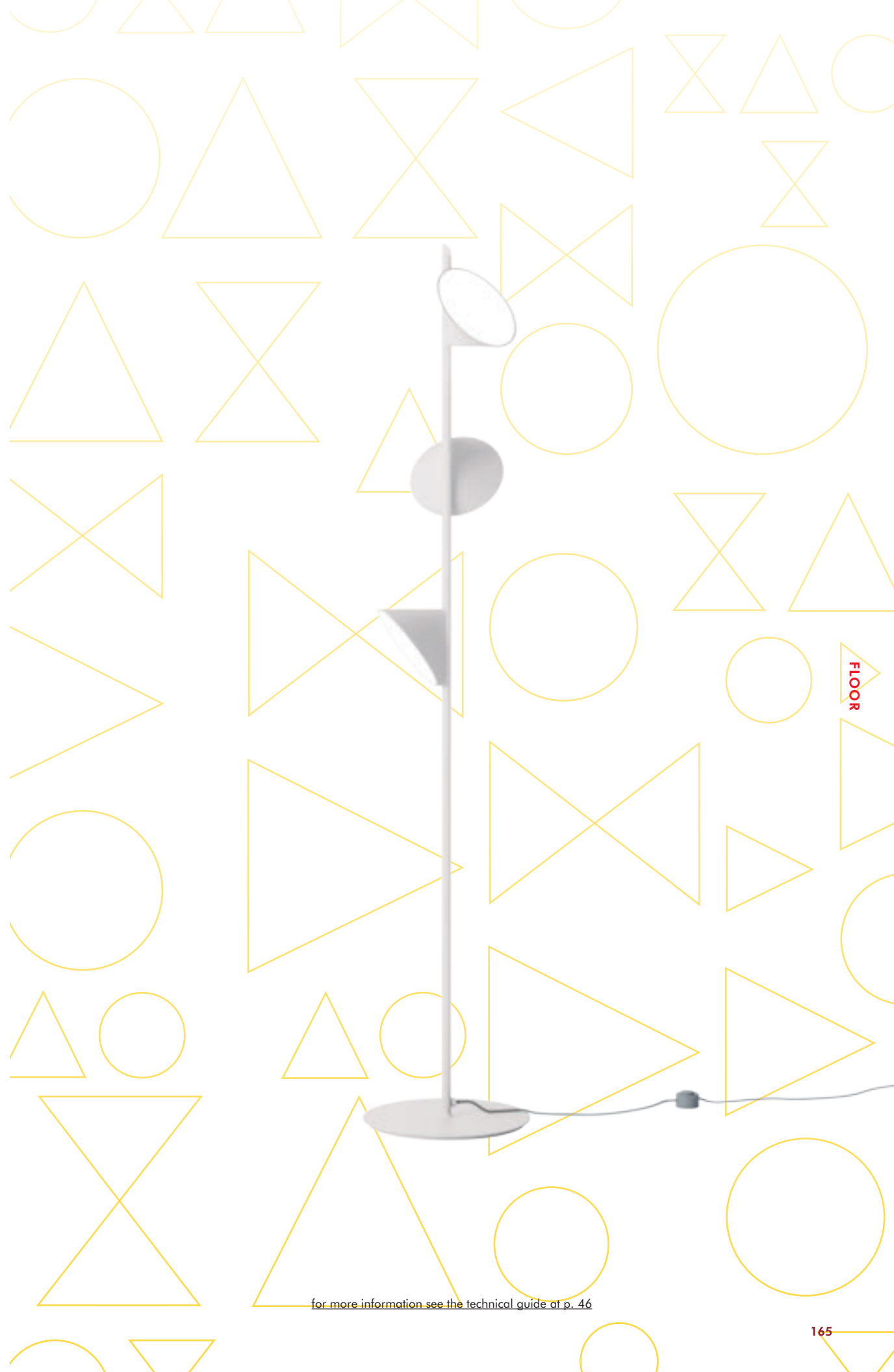

FLOOR

for more information see the technical guide at p. 46



recessed

- CRYSTAL SPOTLIGHT
- FAIRY
- FAVILLA
- FEDORA
- NAFIR
- SPILLRAY



**CRYSTAL SPOTLIGHT**  
design Manuel Vivian



[for more information see the technical guide at p. 18](#)

RECESSED







**FAIRY**  
design Manuel Vivian



for more information see the technical guide at p. 22





**FEDORA**  
design Dima Loginoff

RECESSED

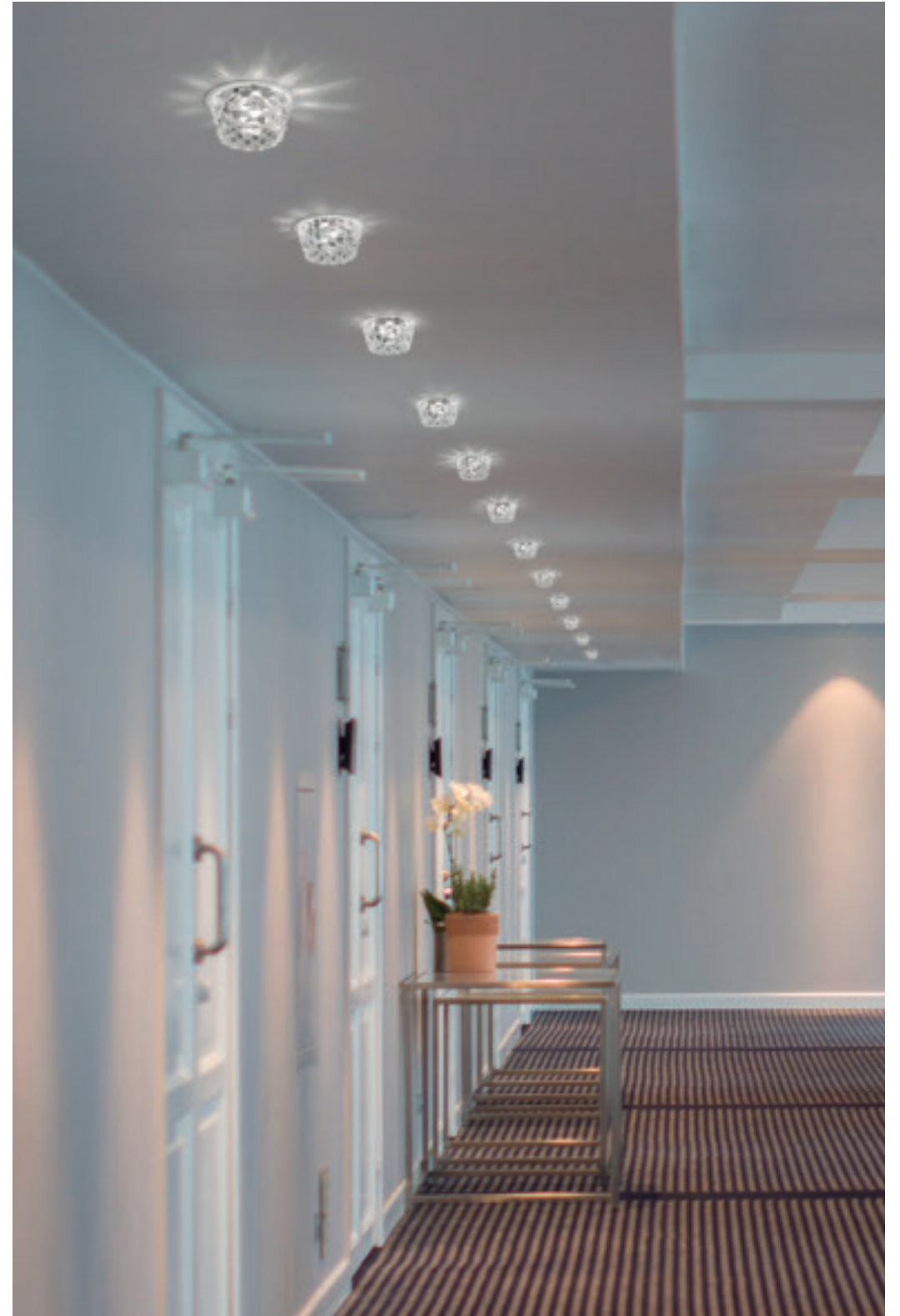

RECESSED

[for more information see the technical guide at p. 26](#)



**NAFIR**  
design Karim Rashid

RECESSED



[for more information see the technical guide at p. 42](#)



**SPILLRAY**  
design Manuel Vivian



[for more information see the technical guide at p. 57](#)

RECESSED

large scale

- ANADEM
- BELL
- EULER
- FRAMEWORK LED
- LAYERS
- MELTING POT
- PLUMAGE
- SHATTER LED
- SKIN
- SKIRT
- U-LIGHT
- VELVET





**ANADEM**  
design Vanessa Vivian



LARGE SCALE



LARGE SCALE

[for more information see the technical guide at p. 6](#)



**BELL**  
design Manuel Vivian



for more information see the technical guide at p. 12





LARGE SCALE



LARGE SCALE



**BELL**  
design Manuel Vivian

LARGE SCALE



for more information see the technical guide at p. 12





LARGE SCALE



LARGE SCALE



**EULER**  
design Cambi Scatena Turini



for more information see the technical guide at p. 18



**FRAMEWORK LED**  
design Manuel Vivian

LARGE SCALE



for more information see the technical guide at p. 28

**FRAMEWORK LED**  
design Manuel Vivian



LARGE SCALE

LARGE SCALE



for more information see the technical guide at p. 28





LARGE SCALE



LARGE SCALE



**MELTING POT**  
design Sandro Santantonio



LARGE SCALE

[for more information see the technical guide at p. 38](#)



**MELTING POT**  
design Sandro Santantonio



LARGE SCALE

for more information see the technical guide at p. 35-37

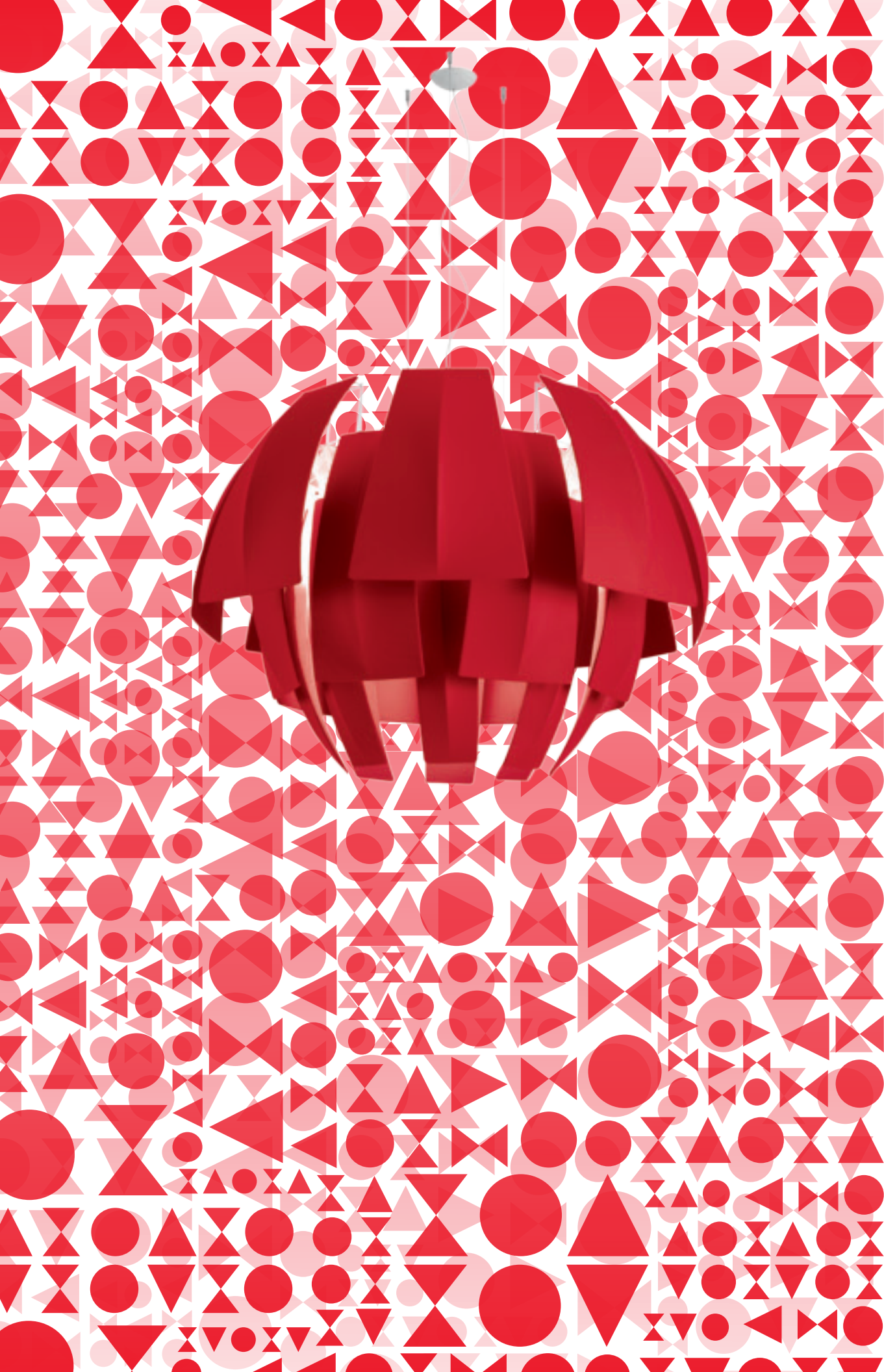

**PLUMAGE**  
design Vanessa Vivian



LARGE SCALE

[for more information see the technical guide at p. 46](#)





LARGE SCALE

**SHATTER LED**  
design Serge & Robert Cornelissen

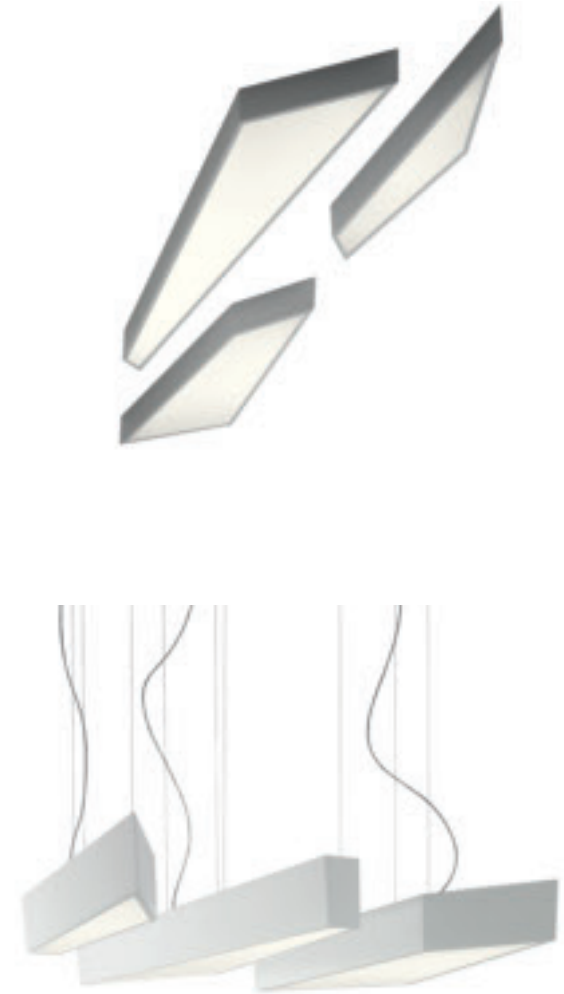

LARGE SCALE

for more information see the technical guide at p. 49-50

**SKIN**  
design Manuel Vivian



LARGE SCALE



for more information see the technical guide at p. 52



**SKIRT**  
design Manuel Vivian



LARGE SCALE

for more information see the technical guide at p. 55



LARGE SCALE



**SKIRT**  
design Manuel Vivian

LARGE SCALE



[for more information see the technical guide at p. 55](#)



**U-LIGHT**  
design Timo Ripatti



LARGE SCALE

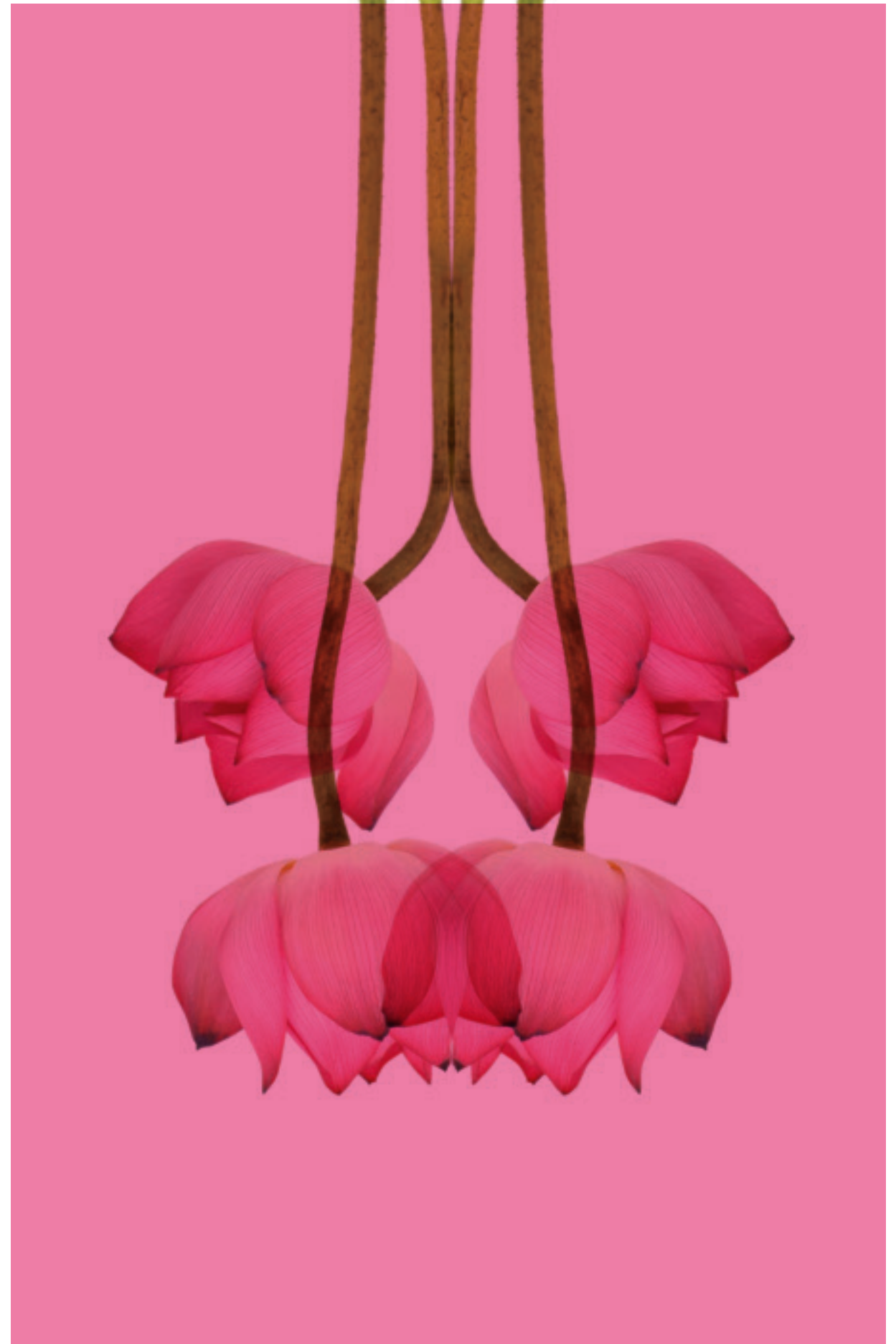

[for more information see the technical guide at p. 68](#)

**U-LIGHT**  
design Timo Ripatti

LARGE SCALE



LARGE SCALE



for more information see the technical guide at p. 68



**U-LIGHT**  
design Timo Ripatti

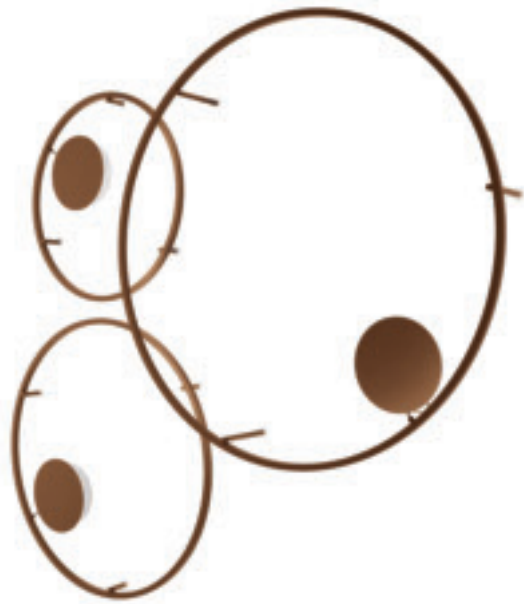
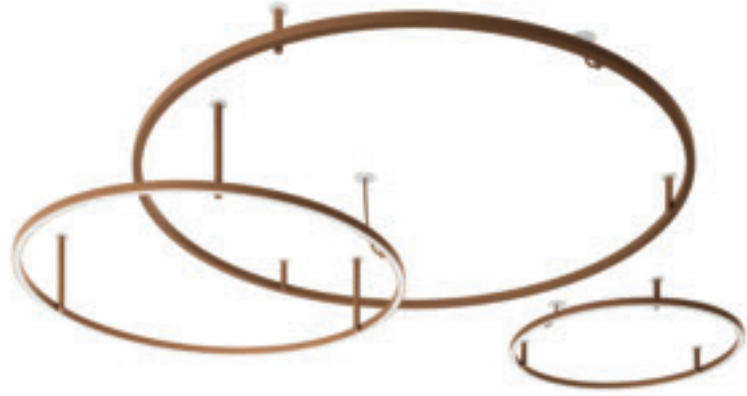

[for more information see the technical guide at p. 65-66](#)





**U-LIGHT**  
design Timo Ripatti

LARGE SCALE



LARGE SCALE

for more information see the technical guide at p. 65



**U-LIGHT**  
design Timo Ripatti

LARGE SCALE



LARGE SCALE



for more information see the technical guide at p. 65





**U-LIGHT**  
design Timo Ripatti

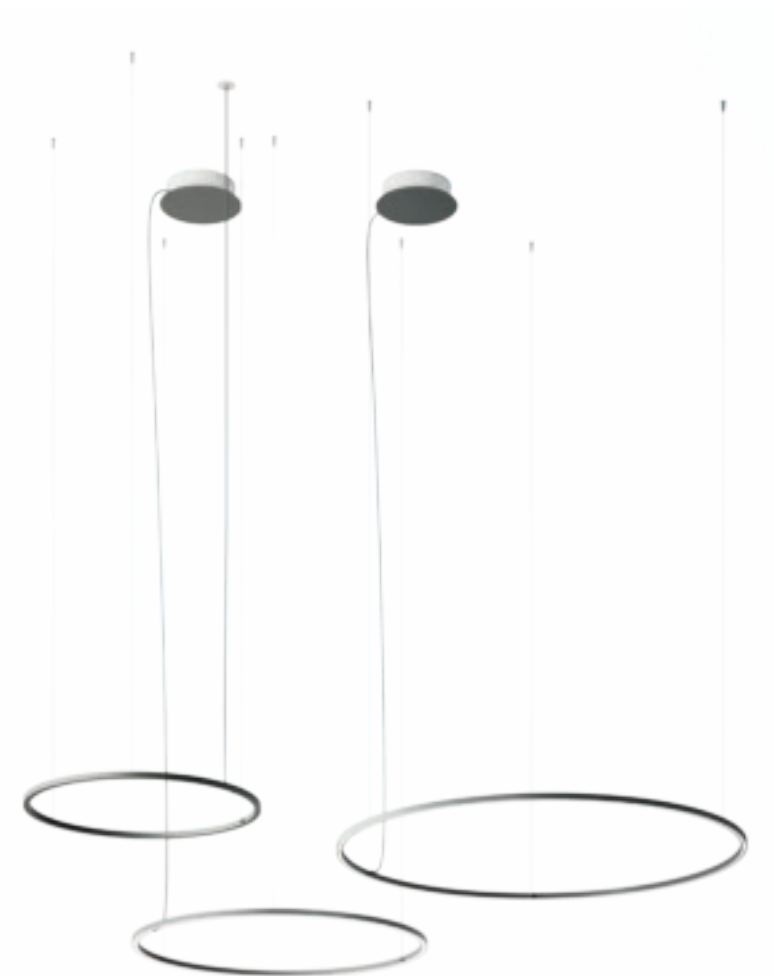

LARGE SCALE



**VELVET**  
design Manuel Vivian



LARGE SCALE

[for more information see the technical guide at p. 75-77](#)



LARGE SCALE

**bespoke**

AURA  
CLAVIUS  
U-LIGHT  
VIRTUS



Restaurant Belvedere / Hergiswil, Switzerland









**AURA**  
design Manuel Vivian

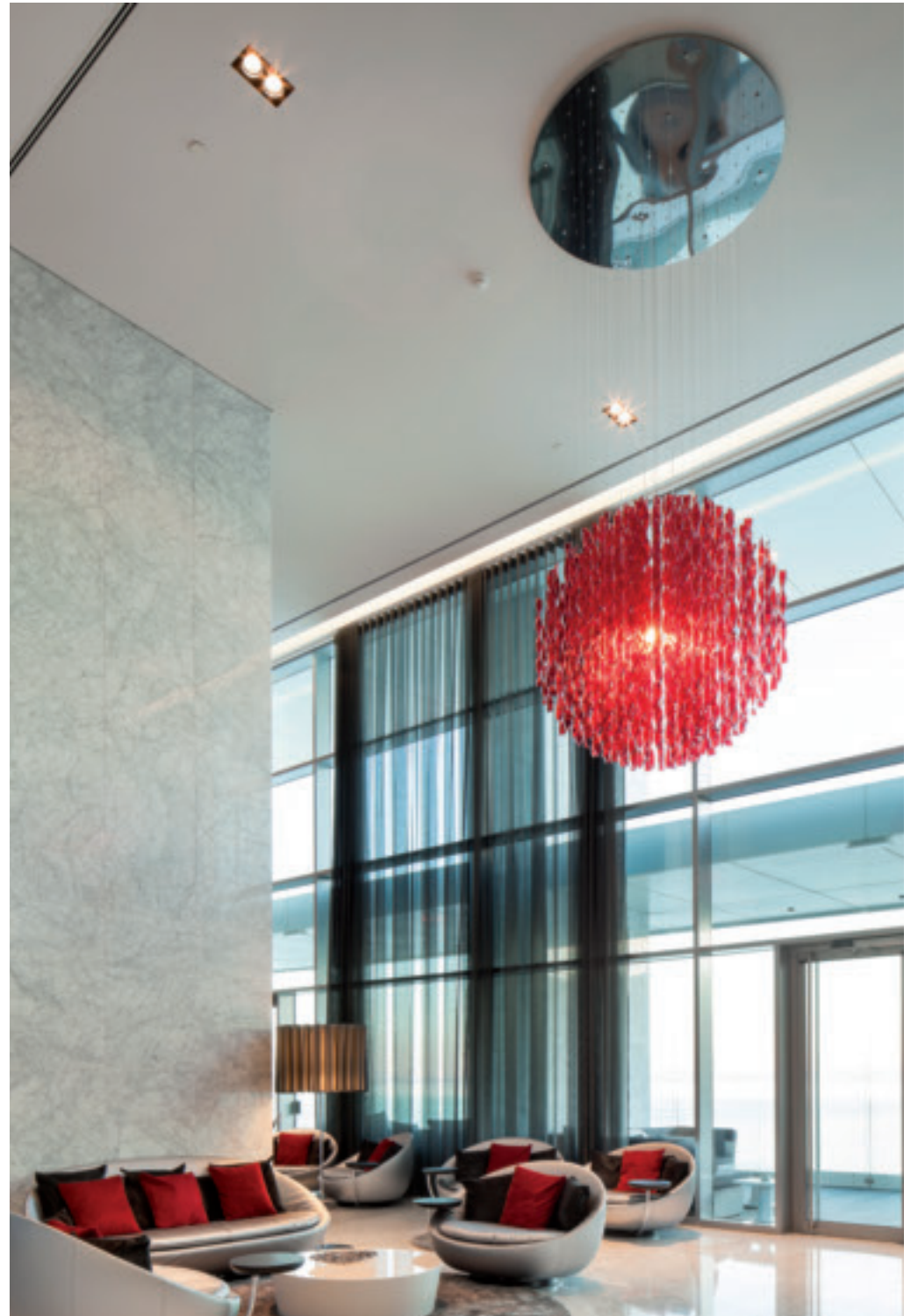

Hotel Myriad, Lisbon - Portugal



**CLAVIUS**  
design Manuel Vivian



BESPOKE

100% Capri / Miami, Usa



BESPOKE



**U-LIGHT**  
design Timo Ripatti

BESPOKE

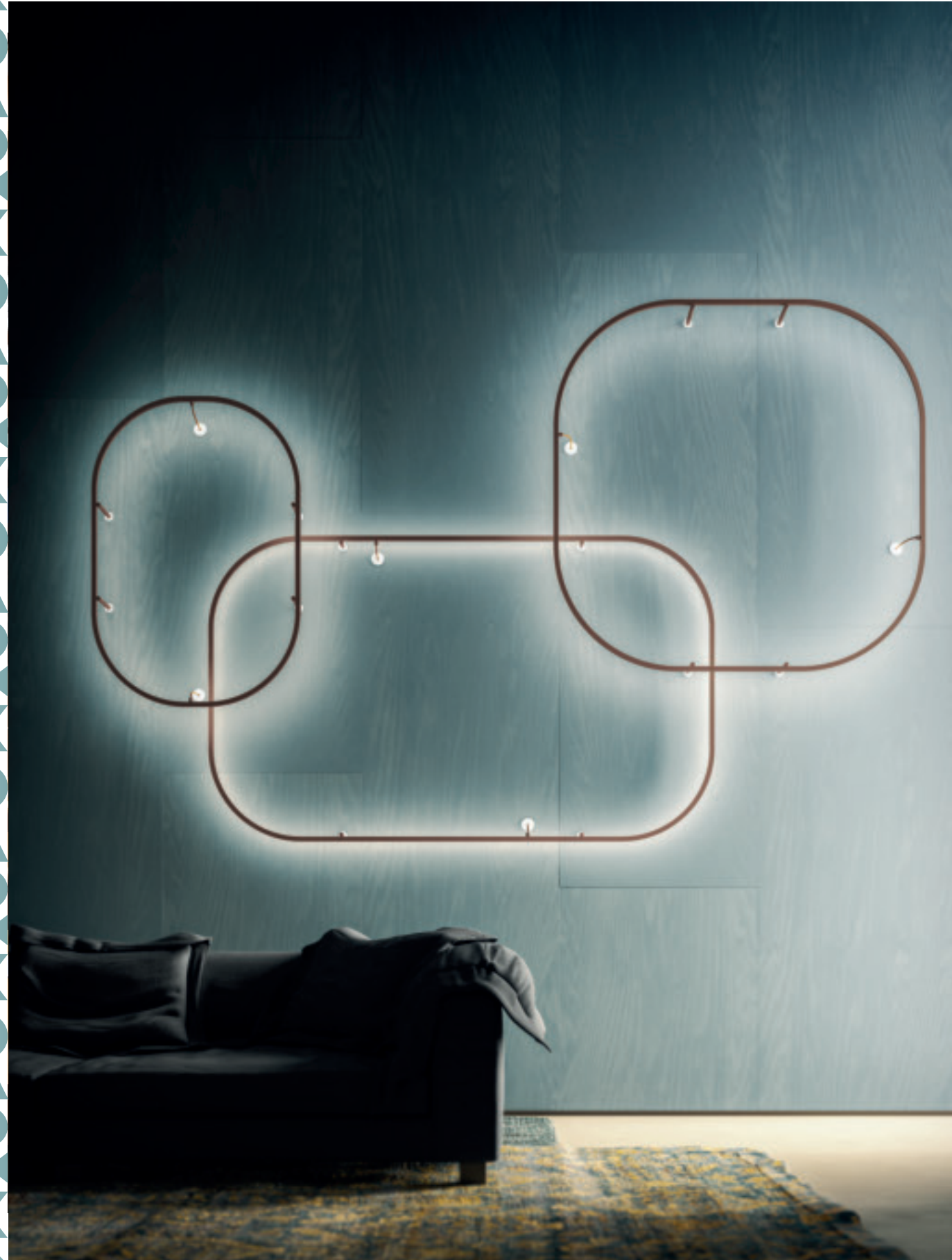
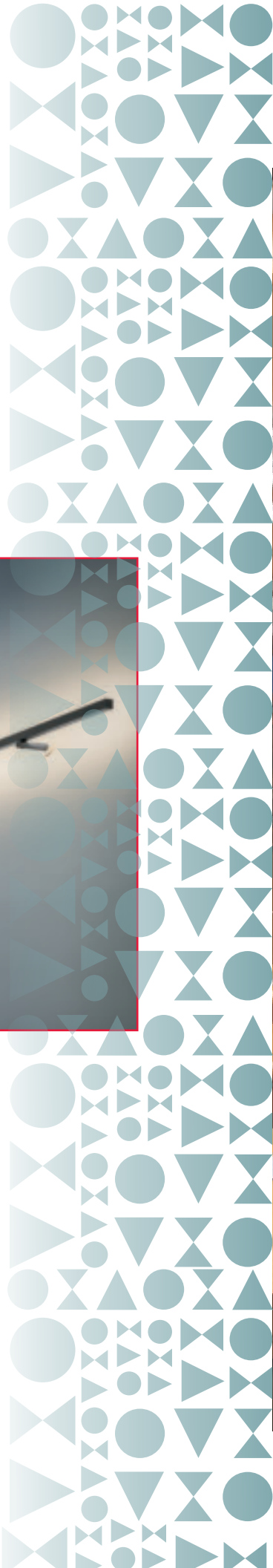



**VIRTUS**  
design Manuel Vivian



BESPOKE

Axo Light si riserva il diritto di apportare ai modelli, senza alcun preavviso, qualsiasi modifica ritenesse opportuna. Axo Light non risponde per eventuali danni a persone o cose causati da una non corretta installazione dei propri apparecchi d'illuminazione. I dati riportati sono puramente indicativi; è possibile che siano riportati degli errori di stampa.

Axo Light reserves itself the right to introduce any changes to its own models, without prior notice. Axo Light is not liable for injuries or damage due to the incorrect installation of its fixtures. The details given here are intended purely as guidance as errors may have occurred during the printing process. Le schede tecniche dei prodotti Axo Light sono scaricabili direttamente dal nostro sito: [www.axolight.it](http://www.axolight.it)

Axo Light technical sheets can be downloaded directly from our website: [www.axolight.it](http://www.axolight.it)

**creative direction/art direction/design/photo illustrations**

TEIKNA DESIGN  
Claudia Neri, creative/design director  
Elisa Stagnoli, design assistant

**editing and coordination**

Fabrizio Cettina

**printed and bound in Italy**

Grafiche Antiga spa

**Renderings**

nudesign srl  
zenzero & co  
neiko srl

**photolito**

Graficart Arti Grafiche srl  
Fotolito Quattrifoglio  
Studio Varianti  
Studio Pointer

**photocredits**

Florindo Romandini  
Studio Varianti  
Studio Pointer  
Bluemotion

AXO LIGHT srl  
via Moglianese, 44  
30037 Scorzè (Venezia) Italy  
t. +39 041 5845193  
f +39 041 5845060  
[axolight@axolight.it](mailto:axolight@axolight.it)  
[axolight.it](http://axolight.it)

AXO LIGHT USA INC.  
22 Shelter Rock Lane, Ste #104  
Danbury, CT, 06810 USA  
t +1 (203) 730 0452  
f +1 (203) 730 0460  
[info@axolightusa.com](mailto:info@axolightusa.com)  
[axolightusa.com](http://axolightusa.com)

AXO LIGHT ASIA LIMITED  
RM305-306, Office Building  
No.2 Tiantaiyi Road  
Science Town, Luogang District  
510663 Guangzhou - PRC  
t +86 20 38316571  
f +86 20 38251165  
[axo.asia@axolight.asia](mailto:axo.asia@axolight.asia)  
[axolight.it](http://axolight.it)

**Axolight** bespoke  
design

Italy  
United States  
China

[axolight.it](http://axolight.it)

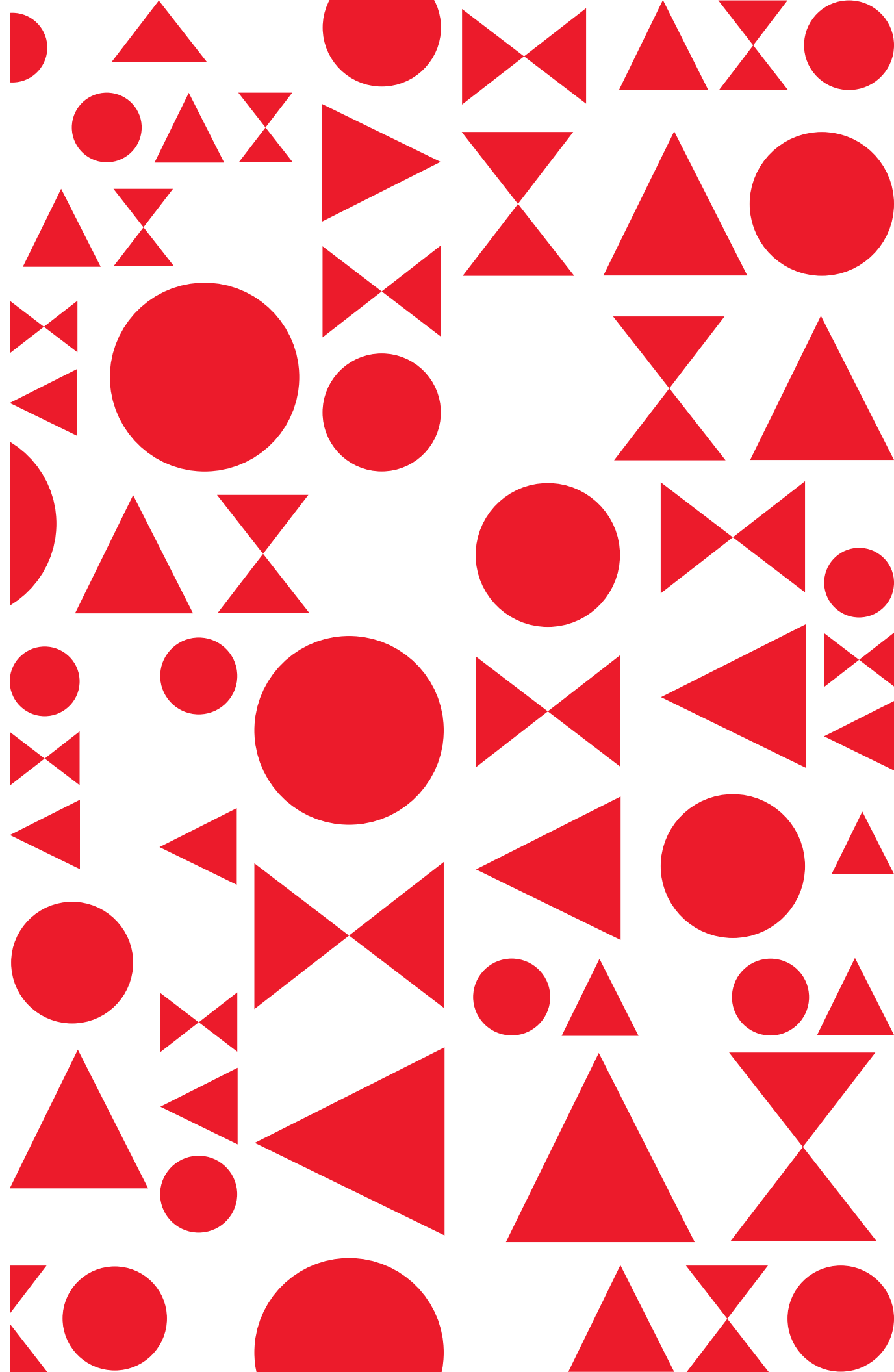







**TECHNICAL INFO**

**2017/18**



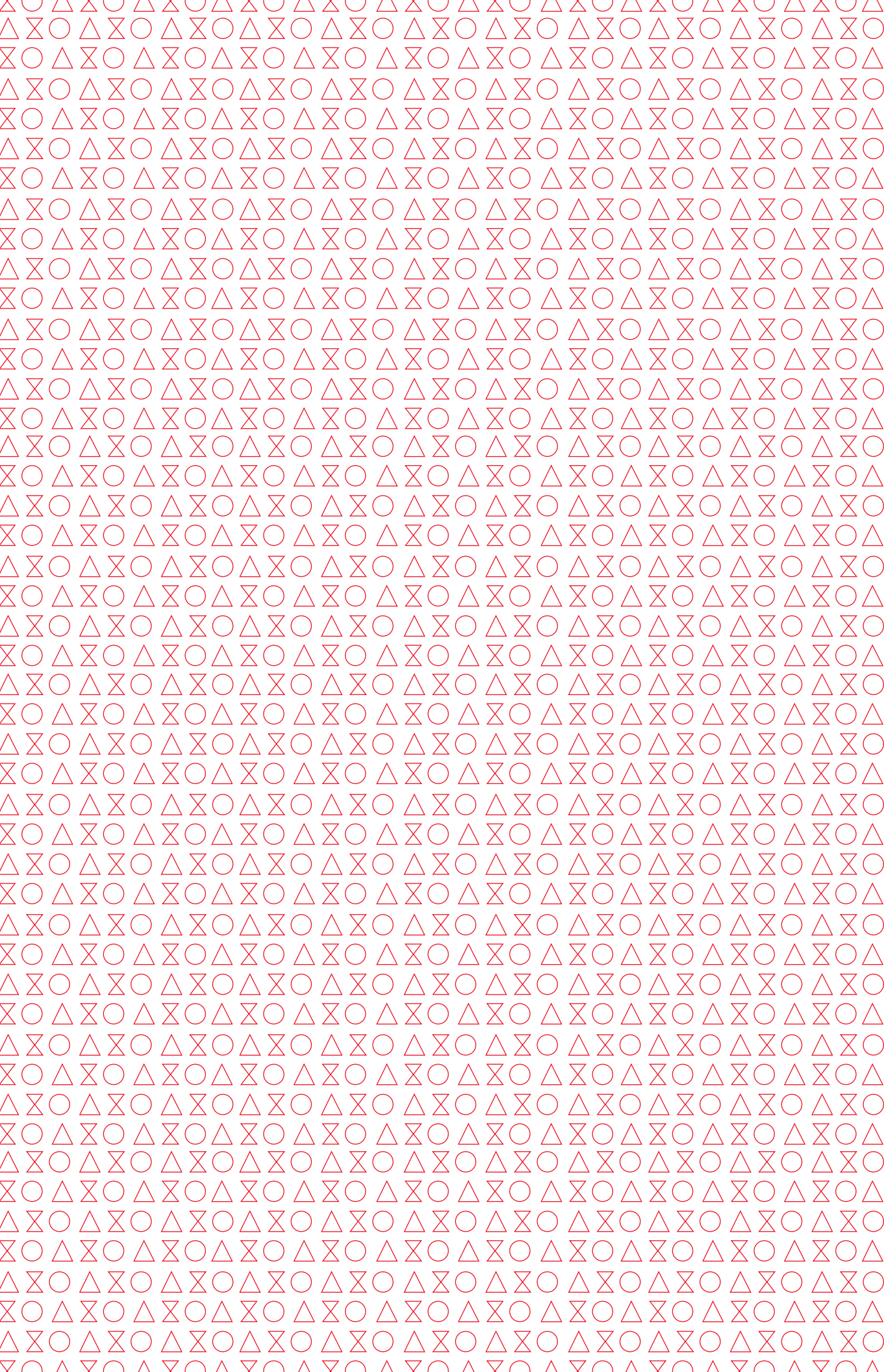

**Axolight** bespoke  
design

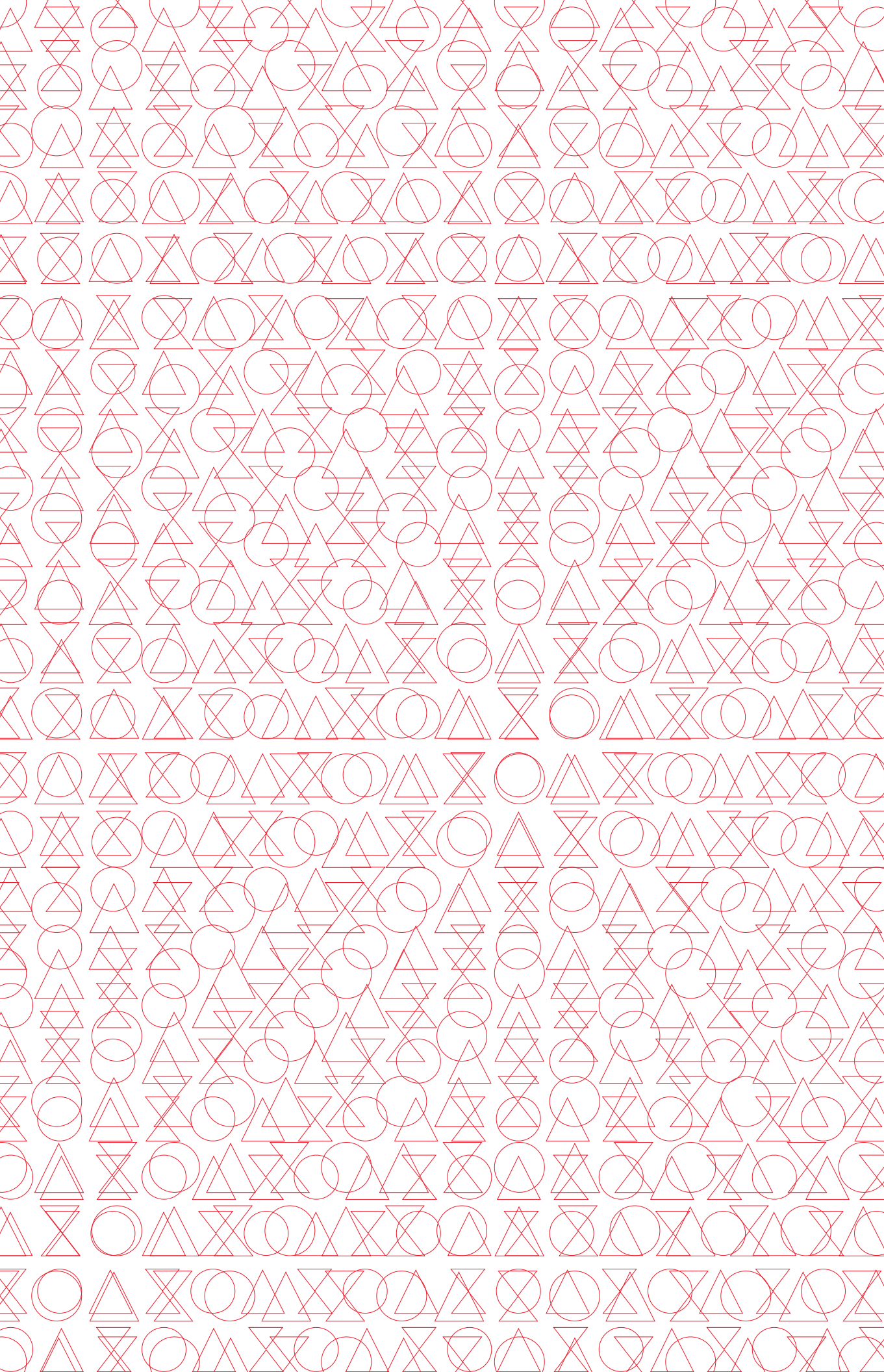

**AIBU**  
page 4

**ALRISHA**  
page 4

**ALYSOID**  
page 5-6

**ANADEM**  
page 6-7

**AURA**  
page 7-9

**AX 20**  
page 10

**BELL**  
page 11-13

**CLAVIUS**  
page 13-17

**CRYSTAL SPOTLIGHT**  
page 18

**EULER**  
page 18-19

**EXPLO**  
page 20-21

**FAIRY**  
page 22-25

**FAVILLA**  
page 25

**FEDORA**  
page 26-27

**FRAMEWORK LED**  
page 28-29

**HOOPS**  
page 30-31

**LAYERS**  
page 32-33

**LIK**  
page 34

**MELTING POT**  
page 34-38

**MOMUS MINI**  
page 38

**MOUNTAIN VIEW**  
page 38

**MUSE**  
page 39-41

**NAFIR**  
page 41-42

**NECKY**  
page 43

**NELLY**  
page 43

**NELLY STRAIGHT**  
page 44

**ORCHID**  
page 44-46

**PLUMAGE**  
page 46-47

**POLIA LED**  
page 48

**RYTHMOS**  
page 48-49

**SHATTER LED**  
page 49-50

**SKIN**  
page 51-52

**SKIRT**  
page 53-57

**SOL**  
page 57

**SPILLRAY**  
page 57-62

**SPIRY**  
page 63

**STILLA**  
page 63

**STORMY**  
page 64

**U-LIGHT**  
page 65-69

**UKIYO**  
page 69

**URBAN**  
page 70-71

**URBAN MINI**  
page 72-74

**URIEL**  
page 74

**VASILY**  
page 74

**VELVET**  
page 75-77

**VIRTUS**  
page 77

**VOLUPTAS**  
page 78

**LEGEND**  
page 80

**EEL COMPATIBILITY**  
page 82-83

**CREDITS**  
page 84-85



## Aibu

design Giovanni Barbato

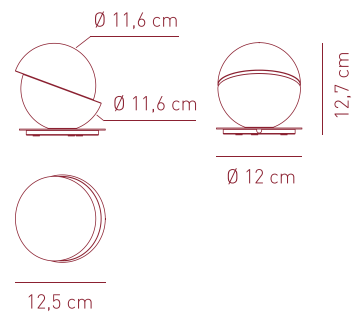

Table lamp in white triplex handmade blown glass.  
*Lampada da tavolo in vetro triplex soffiato e lavorato a mano, bianco.*

### LT AIBU

**Source:**  
**G9** 1 x Max 2,5W only LED bulb

CE IP20 LED

### COLOURS

white

## Alrisha

design Brian Rasmussen

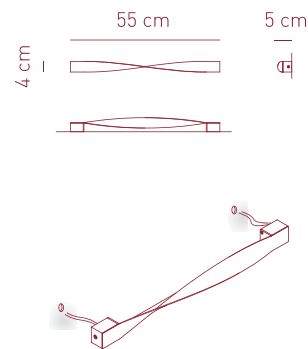

Collection consisting of white painted aluminium suspended lamp and wall lamp.  
*Collezione composta da lampada da parete e a sospensione in alluminio verniciato bianco.*

### AP ALRISHA

**Source:**  
**LED** 3W - 500mA - 3000K  
CRI 80 - ~154 lm - 51 lm/W

CE IP20 with dedicated PSU ADA LED

### COLOUR

wrinkled white

Driver not included

For drivers and dimming technology, please refer to our Axo Light pricelist or contact our representatives

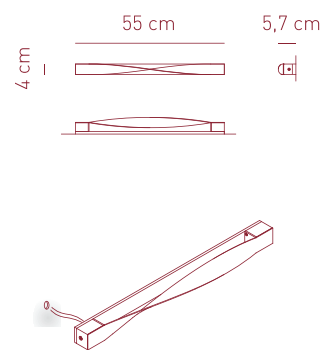

### AP ALRISP with wall mounting box

**Source:**  
**LED** 3W - 500mA - 3000K  
CRI 80 - ~154 lm - 51 lm/W

CE IP20 with dedicated PSU ADA LED

### COLOUR

wrinkled white

Driver not included

For drivers and dimming technology, please refer to our Axo Light pricelist or contact our representatives

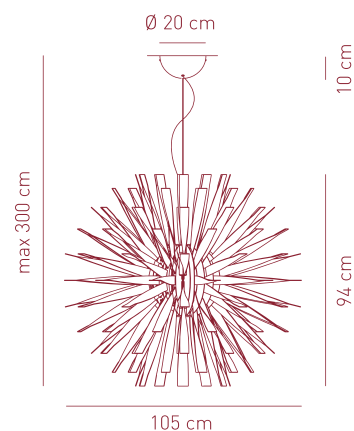

### SP ALRISHA

**Source:**  
**E27** 1 x Max 20W LED or  
1 x Max 32W fluo or  
1 x Max 150W halo

CE IP20 +LED

### COLOUR

wrinkled white

### FINISH

white canopy

## Alysoid

design Ryoosuke Fukusada

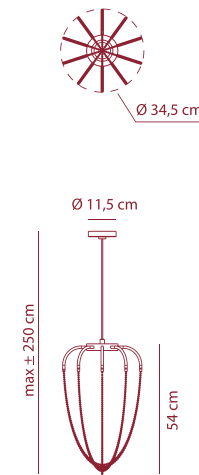

Collection consisting of aluminium suspended lamps. Available in several colours and sizes. Built-in dimmable LED light source.

*Collezione di lampade a sospensione in alluminio. Disponibile in vari colori e dimensioni. La sorgente luminosa è a LED integrato dimmerabile.*

### SP ALYS 34

**Source:**  
**LED** 20W - diffused beam - 3000K  
CRI 90 - ~1230 lm - 60 lm/W

CE IP20 dimmable phase cut

220-240VAC LED

### COLOURS

anthracite grey wrinkled/  
chains: black polished nickel

anthracite grey wrinkled/  
chains: natural brass

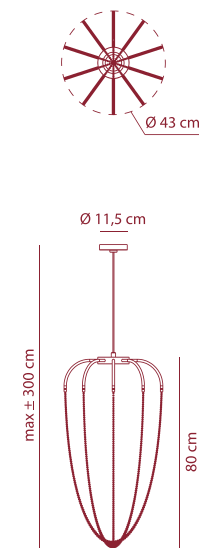

### SP ALYS 43

**Source:**  
**LED** 20W - diffused beam - 3000K  
CRI 90 - ~1230 lm - 60 lm/W

CE IP20 dimmable phase cut

220-240VAC LED

### COLOURS

anthracite grey wrinkled/  
chains: black polished nickel

anthracite grey wrinkled/  
chains: natural brass

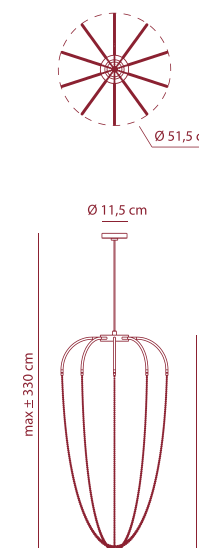

### SP ALY 51 P

**Source:**  
**LED** 20W - diffused beam - 3000K  
CRI 90 - ~1230 lm - 60 lm/W

CE IP20 dimmable phase cut

220-240VAC LED

### COLOURS

anthracite grey wrinkled/  
chains: black polished nickel

anthracite grey wrinkled/  
chains: natural brass

## Alysoid

design Ryosuke Fukusada

Collection consisting of aluminium suspended lamps. Available in several colours and sizes. Built-in dimmable LED light source.  
*Collezione di lampade a sospensione in alluminio. Disponibile in vari colori e dimensioni. La sorgente luminosa è a LED integrato dimmerabile.*

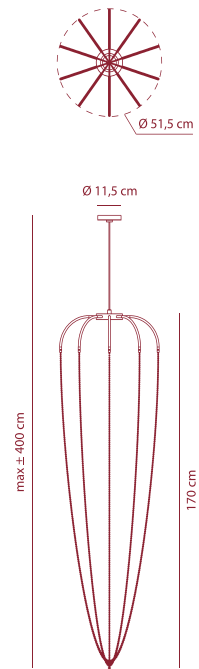

### SP ALY 51 G

**Source:**  
**LED** 20W - diffused beam - 3000K  
 CRI 90 - ~1230 lm - 60 lm/W

CE IP20 dimmable DALI  
 220-240VAC **LED**

### COLOURS

- anthracite grey wrinkled/  
chains: black polished nickel
- anthracite grey wrinkled/  
chains: natural brass

### SP ANA 150

**Source:**  
**E27** 6 x Max 16W LED or  
 6 x Max 20W fluo or  
 6 x Max 70W halo

CE IP20 **+LED**

**FLUO** GX24q-4 6 x 42W

CE IP20 dimmable DALI

### COLOURS

- ivory white

### FINISH

- white canopy

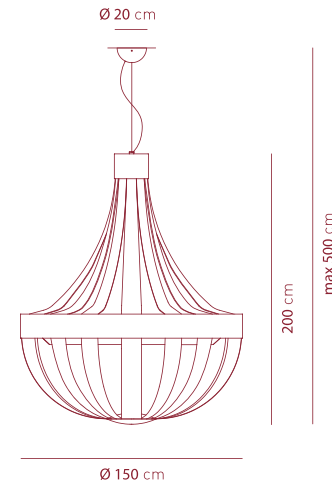

## Aura

design Manuel Vivian

Collection consisting of wall lamps, ceiling lamps and suspended lamps with double-layered coloured Murano glass hand twisted pendants.

*Collezione composta da lampade da parete, lampade da soffitto, lampade a sospensione, con pendenti in vetro di Murano colorato incamiciato cristallo e ritorti a mano.*

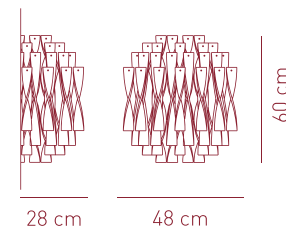

### AP AURA

**Source:**  
**E27** 2 x Max 20W LED or  
 2 x Max 30W fluo or  
 2 x Max 100W halo

CE IP20 **+LED**

### COLOURS

- "rigadin" crystal
- red
- white
- tea

### FINISH

- polished chrome
- gold leaf

## Anadem

design Vanessa Vivian

Collection consisting of suspended lamps in flame-retardant eco-leather finish. Available in several colours and sizes. Screw fitting light source.

*Collezione di lampade a sospensione con finitura in ecopelle ignifuga. Disponibile in vari colori e dimensioni. Sorgente luminosa con attacco a vite.*

### COMPOSITION/COMPOSIZIONE

Flame retardant Eco-leather - 87% PVC + 13% polyester  
 Extra smooth flame retardant pongé fabric - 100% polyester

Tessuto ignifugato pongé superliscio - 100% poliestere  
 Eco pelle ignifuga - 87% PVC + 13% poliestere

Glow Wire Test (EN 60598-1): 960°C

### WEIGHT/PESO

550 ± 5% gr/m<sup>2</sup>

### AVAILABLE UPON REQUEST

- brown
- red
- brown+white

### SP ANA 090

**Source:**  
**E27** 4 x Max 16W LED or  
 4 x Max 20W fluo or  
 4 x Max 70W halo

CE IP20 **+LED**

**FLUO** GX24q-4 4 x 42W

CE IP20 dimmable DALI

### COLOURS

- ivory white

### FINISH

- white canopy

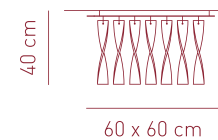
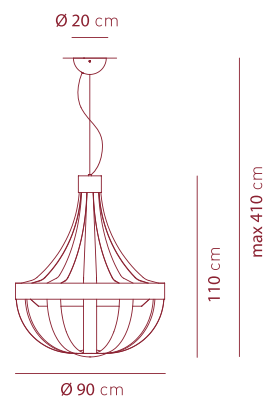

### PL AUR P 30

**Source:**  
**E27** 4 x Max 20W LED or  
 4 x Max 30W fluo or  
 4 x Max 100W halo

CE IP20 **+LED**

### COLOURS

- "rigadin" crystal
- red
- white
- tea

### FINISH

- polished chrome
- gold leaf



# Aura

design Manuel Vivian

Collection consisting of wall lamps, ceiling lamps and suspended lamps with double-layered coloured Murano glass hand twisted pendants.

Collezione composta da lampade da parete, lampade da soffitto, lampade a sospensione, con pendenti in vetro di Murano colorato incamiciato cristallo e ritorti a mano.

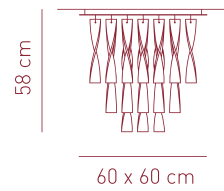

## PL AURA P

**Source:**  
**E27** 4 x Max 20W LED or  
 4 x Max 30W fluo or  
 4 x Max 100W halo

CE IP20 +LED

## COLOURS



## FINISH

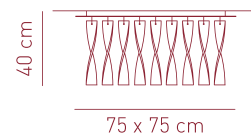
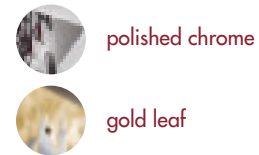

## PL AUR G 30

**Source:**  
**E27** 4 x Max 20W LED or  
 4 x Max 30W fluo or  
 4 x Max 100W halo

CE IP20 +LED

## COLOURS



## FINISH

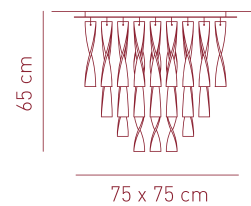
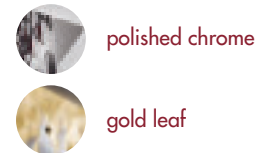

## PL AURA GR

**Source:**  
**E27** 4 x Max 20W LED or  
 4 x Max 30W fluo or  
 4 x Max 100W halo

CE IP20 +LED

## COLOURS



## FINISH

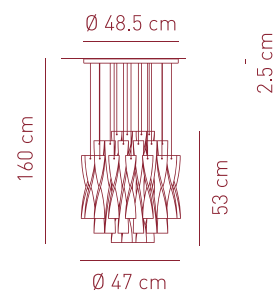
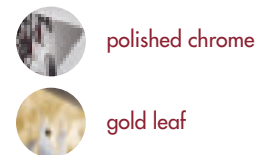

## SP AURA 45

**Source:**  
**E27** 1 x Max 27W LED or  
 1 x Max 40W fluo or  
 1 x Max 150W halo

CE IP20 +LED

## COLOURS



## FINISH

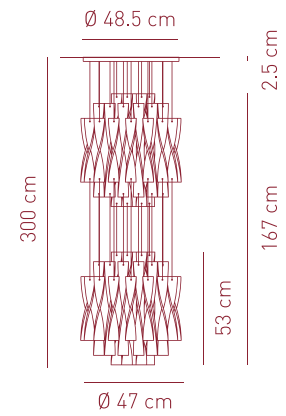

## SP AU 45/2

**Source:**  
**E27** 2 x Max 20W LED or  
 2 x Max 23W fluo or  
 2 x Max 150W halo

CE IP20 +LED

## COLOURS



## FINISH

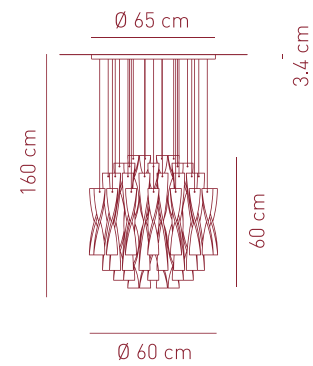

## SP AURA 60

**Source:**  
**E27** 1 x Max 35W LED or  
 1 x Max 60W fluo or  
 1 x Max 250W halo

CE IP20 +LED

## COLOURS



## FINISH

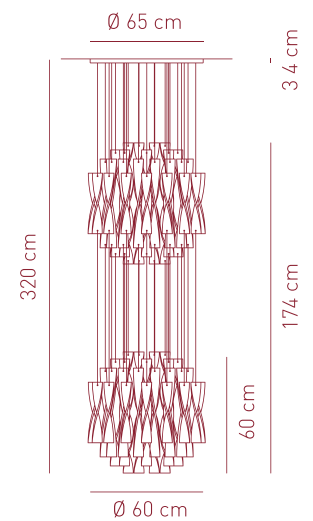

## SP AURA 60/2

**Source:**  
**E27** 2 x Max 20W LED or  
 2 x Max 23W fluo or  
 2 x Max 250W halo

CE IP20 +LED

## COLOURS



## FINISH



## Ax 20

design Manuel Vivian

Collection consisting of wall lamps, suspended lamps, floor lamps and table lamps with chrome-plated finish.

Collezione composta da lampade da parete, lampade a sospensione, lampade da terra e da tavolo in metallo cromato.

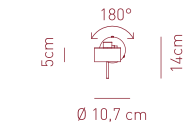
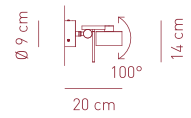

### AP AX20 PI

### COLOUR

Source:  
G9 1 x Max 60W halo

● chrome

CE IP20

### AP AX20 GR

### COLOUR

Source:  
G9 1 x Max 60W halo

● chrome

CE IP20

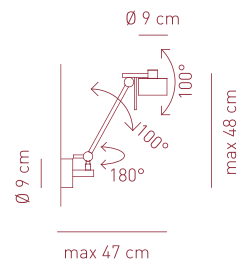

### SP AX20 PI

### COLOUR

Source:  
G9 1 x Max 60W halo

● chrome

CE IP20

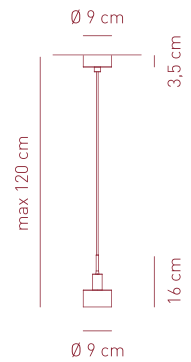

### PT AX20

### COLOUR

Source:  
G9 1 x Max 60W halo

● chrome

CE IP20 dimmable

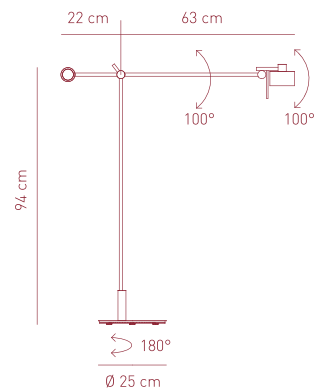

### LT AX20

### COLOUR

Source:  
G9 1 x Max 60W halo

● chrome

CE IP20 dimmable

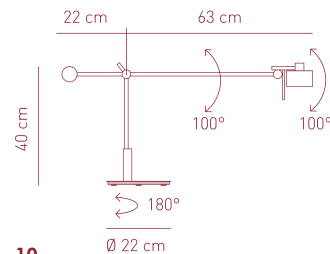

## Bell

design Manuel Vivian

Collection consisting of ceiling lamps and suspended lamps with a metal frame covered with strips of extra smooth flame-retardant pongé fabric. Available in several colours and sizes. Screw fitting or built-in dimmable LED light source.

Collezione di lampade da soffitto e lampade a sospensione con struttura metallica rivestita con fettuccia di tessuto ignifugato pongé superliscio. Disponibile vari colori e dimensioni. Sorgente luminosa con attacco a vite o a LED integrato dimmerabile.

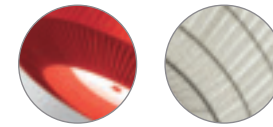

### COMPOSITION/COMPOSIZIONE

Extra smooth flame retardant pongé fabric - 100% polyester  
Tessuto ignifugato pongé superliscio - 100% poliestere

Glow Wire Test (EN 60598-1): 960°C

### WEIGHT/PESO

55 ± 5% gr/m<sup>2</sup>

### AVAILABLE UPON REQUEST



### PL BEL 060

### COLOURS

Source:  
E27 2 x Max 16W LED or  
2 x Max 23W fluo or  
2 x Max 57W halo

○ white

CE IP20 +LED

Diffuser included



### PL BEL 090

### COLOURS

Source:  
E27 3 x Max 16W LED or  
3 x Max 23W fluo or  
3 x Max 57W halo

○ white

CE IP20 +LED

Diffuser included

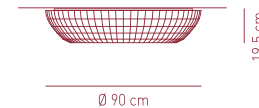

### PL BEL 118

### COLOURS

Source:  
E27 4 x Max 16W LED or  
4 x Max 23W fluo or  
4 x Max 57W halo

○ white

CE IP20 +LED

Diffuser included

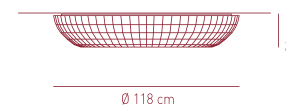

### PL BEL 180

### COLOURS

Source:  
E27 5 x Max 16W LED or  
5 x Max 23W fluo or  
5 x Max 46W halo

○ white

CE IP20 +LED

Diffuser included

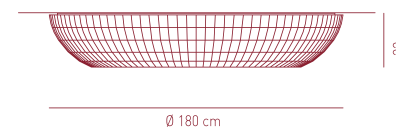



## Bell

design Manuel Vivian

Collection consisting of ceiling lamps and suspended lamps with a metal frame covered with strips of extra smooth flame-retardant pongé fabric. Available in several colours and sizes. Screw fitting or built-in dimmable LED light source.

Collezione di lampade da soffitto e lampade a sospensione con struttura metallica rivestita con fettuccia di tessuto ignifugato pongé superliscio. Disponibile vari colori e dimensioni. Sorgente luminosa con attacco a vite o a LED integrato dimmerabile.

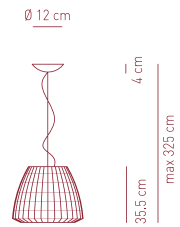

Ø 45 cm

### SP BEL 045

#### COLOURS



#### Source:

**E27** 1 x Max 20W LED or  
1 x Max 33W fluo or  
1 x Max 70W halo

CE IP20 +LED

Diffuser not included

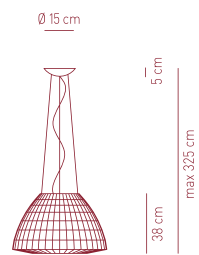

Ø 60 cm

### SP BEL 060

#### COLOURS



#### Source:

**E27** 1 x Max 20W LED or  
1 x Max 33W fluo or  
1 x Max 70W halo

CE IP20 +LED

Diffuser not included

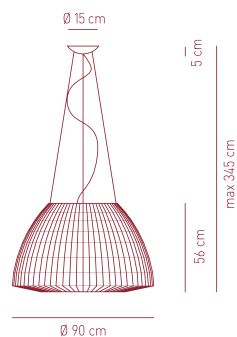

Ø 90 cm

### SP BEL 090

with upward & downward lighting

#### COLOURS



#### Source:

**E27** 4 x Max 20W LED or  
4 x Max 33W fluo or  
4 x Max 46W halo

CE IP20 +LED

Diffuser included

**LED** 75W - diffused beam - 3000K  
CRI 90 - ~6290 lm - 83 lm/W

CE IP20 dimmable DALI +LED

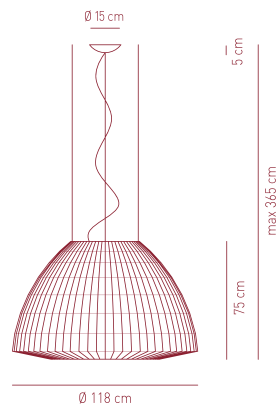

Ø 118 cm

### SP BEL 118

with upward & downward lighting

#### COLOURS



#### Source:

**E27** 4 x Max 20W LED or  
4 x Max 33W fluo or  
4 x Max 57W halo

CE IP20 +LED

Diffuser included

**LED** 95W - diffused beam - 3000K  
CRI 90 - ~6490 lm - 68 lm/W

CE IP20 dimmable DALI +LED

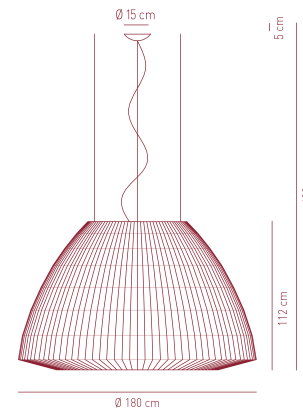

### SP BEL 180

with upward & downward lighting

#### COLOURS



#### Source:

**E27** 4 x Max 16W + 1 x Max 9,5W LED or  
5 x Max 23W fluo or  
4 x Max 57W + 1 x Max 46W halo

CE IP20 +LED

Diffuser included

**LED** 95W - diffused beam - 3000K  
CRI 90 - ~5252 lm - 55 lm/W

CE IP20 dimmable DALI +LED

## Clavius

design Manuel Vivian

Collection consisting of wall lamps, ceiling lamps, suspended lamps, table lamps and floor lamp. Metal frame and hand-made silken thread lampshade.

Collezione composta da lampade da parete, lampade da soffitto, lampade a sospensione, lampade da tavolo e lampada da terra con montatura in metallo e paralume lavorato a mano con fili setati.

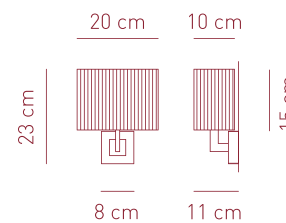

### AP CLAV BR

#### COLOURS



#### Source:

**E14** 1 x Max 6,5W LED or  
1 x Max 12W fluo or  
1 x Max 42W halo

CE IP20 +LED

#### FINISH

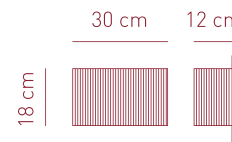
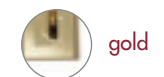

### AP CLAV 30

#### COLOURS



#### Source:

**E14** 1 x Max 6,5W LED or  
1 x Max 12W fluo or  
1 x Max 42W halo

CE IP20 +LED

#### FINISH

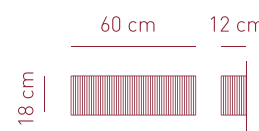

### AP CLAV PI

#### COLOURS



#### Source:

**E14** 2 x Max 6,5W LED or  
2 x Max 12W fluo or  
2 x Max 42W halo

CE IP20 +LED

#### FINISH



# Clavius

design Manuel Vivian

Collection consisting of wall lamps, ceiling lamps, suspended lamps, table lamps and floor lamp. Metal frame and hand-made silken thread lampshade.

Collezione composta da lampade da parete, lampade da soffitto, lampade a sospensione, lampade da tavolo e lampada da terra con montatura in metallo e paralume lavorato a mano con fili setati.

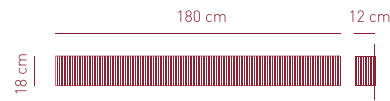

## AP CLAV GR

**Source:**  
**E14** 6 x Max 6,5W LED or  
 6 x Max 12W fluo or  
 6 x Max 42W halo

CE IP20 +LED

Diffuser included

## COLOURS

white tobacco

sand

## FINISH

white

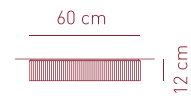

## PL CLAVIU

**Source:**  
**E27** 3 x Max 9,5W LED or  
 3 x Max 12W fluo or  
 3 x Max 46W halo

CE IP20 +LED

Diffuser included

## COLOURS

white tobacco

sand

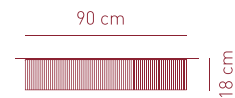

## PL CLAV 90

**Source:**  
**E27** 3 x Max 16W LED or  
 3 x Max 23W fluo or  
 3 x Max 70W halo

CE IP20 +LED

Diffuser included

## COLOURS

white tobacco

sand

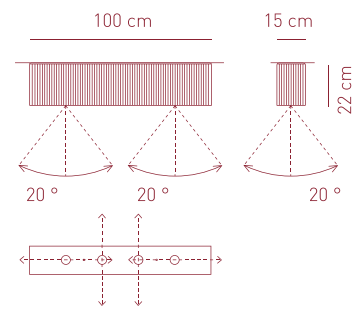

## PL CLA 100

**Source:**  
**LED** 4 x 10,2W - 40° - 2700K  
 CRI 80 - ~4 x ~1015 lm - 99 lm/W

CE IP20 - dimmable + LED

## COLOURS

white tobacco

sand

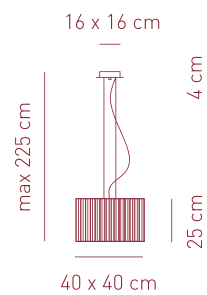

## SP CLAV 40

**Source:**  
**E27** 4 x Max 6,5W LED or  
 4 x Max 12W fluo or  
 4 x Max 46W halo

CE IP20 +LED

## COLOURS

white tobacco

sand

## FINISH

chrome

gold

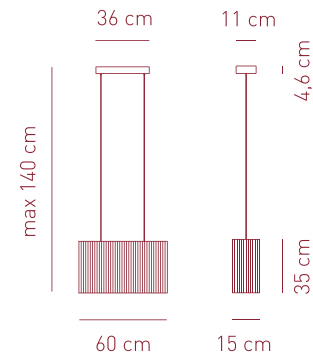

## SP CLAVI P

**Source:**  
**E27** 2 x Max 16W LED or  
 2 x Max 21W fluo or  
 2 x Max 70W halo

CE IP20 +LED

Diffuser included

## COLOURS

white tobacco

sand

## FINISH

chrome

gold

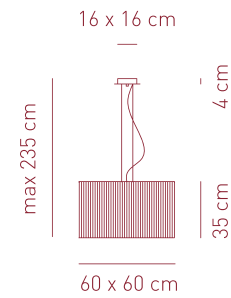

## SP CLAV 60

**Source:**  
**E27** 4 x Max 16W LED or  
 4 x Max 21W fluo or  
 4 x Max 70W halo

CE IP20 +LED

Diffuser included

## COLOURS

white tobacco

sand

## FINISH

chrome

gold

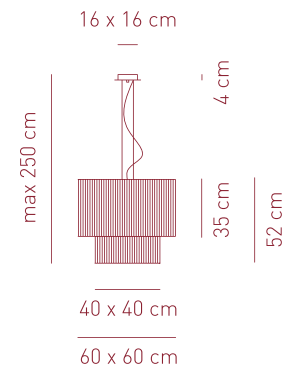

## SP CL 60 40

**Source:**  
**E27** 4 x Max 16W LED or  
 4 x Max 21W fluo or  
 4 x Max 70W halo

CE IP20 +LED

Diffuser included

## COLOURS

white tobacco

sand

## FINISH

chrome

gold

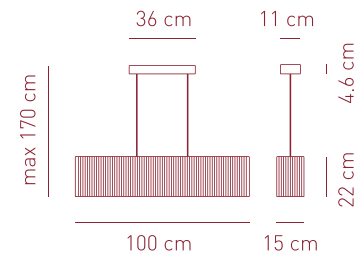

## SP CLAVIU LED

**Source:**  
**LED** 34,2W - 2700K  
 CRI 80 - ~3470 lm - 101 lm/W

CE IP20 - dimmable DALI + LED

Diffuser not included (optional)

## COLOURS

white tobacco

sand

## FINISH

chrome

gold



# Clavius

design Manuel Vivian

Collection consisting of wall lamps, ceiling lamps, suspended lamps, table lamps and floor lamp. Metal frame and hand-made silken thread lampshade.

Collezione composta da lampade da parete, lampade da soffitto, lampade a sospensione, lampade da tavolo e lampada da terra con montatura in metallo e paralume lavorato a mano con fili setati.

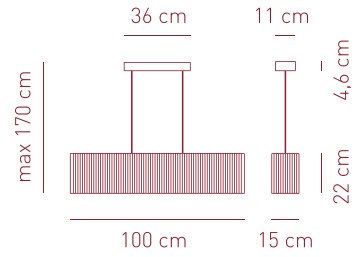

## SP CLAVIU FLE

Source:  
**FLUO** G5 1 x 39W

CE IP20

Diffuser not included (optional)

## COLOURS

white tobacco

sand

## FINISH

chrome

gold

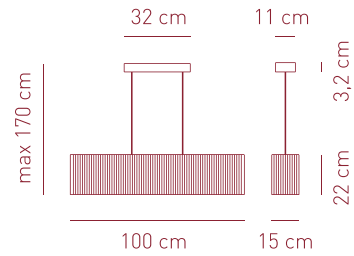

## SP CLAVIU E27

Source:  
**E27** 3 x Max 16W LED or  
3 x Max 21W fluo or  
3 x Max 70W halo

CE IP20 +LED

Diffuser not included (optional)

## COLOURS

white tobacco

sand

## FINISH

chrome

gold

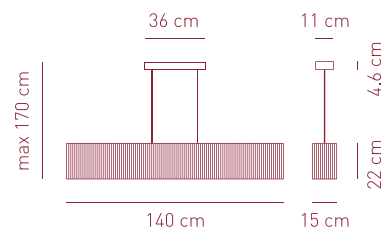

## SP CLA 140 LED

Source:  
**LED** 45,6W - 2700K  
CRI 80 - ~4626 lm - 101 lm/W

CE IP20 dimmable DALI +LED

Diffuser not included (optional)

## COLOURS

white tobacco

sand

## FINISH

chrome

gold

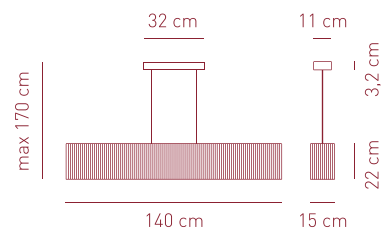

## SP CLA 140 E27

Source:  
**E27** 4 x Max 16W LED or  
4 x Max 21W fluo or  
4 x Max 70W halo

CE IP20 +LED

## COLOURS

white tobacco

sand

## FINISH

chrome

gold

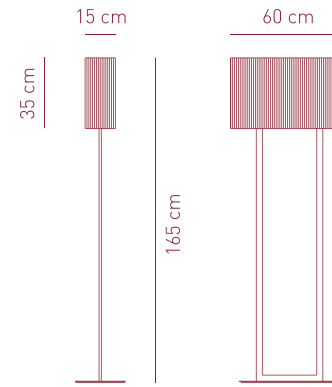

## PT CLAVIU

Source:  
**E27** 2 x Max 16W LED or  
2 x Max 21W fluo or  
2 x Max 70W halo  
(dimmable lamps required)

CE IP20 dimmable +LED

## COLOURS

white tobacco

sand

## FINISH

chrome

gold

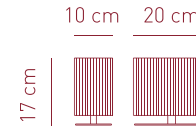

## LT CLAV XP

Source:  
**E14** 1 x Max 6,5W LED or  
1 x Max 12W fluo or  
1 x Max 42W halo

CE IP20 +LED

## COLOURS

white tobacco

sand

## FINISH

chrome

gold

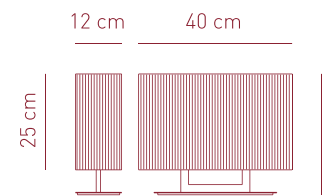

## LT CLAVI P

Source:  
**E14** 2 x Max 6,5W LED or  
2 x Max 12W fluo or  
2 x Max 42W halo

CE IP20 +LED

## COLOURS

white tobacco

sand

## FINISH

chrome

gold

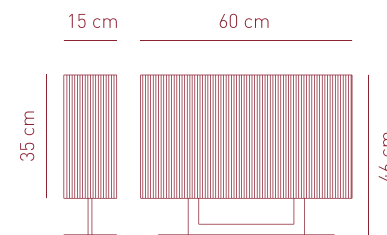

## LT CLAVI G

Source:  
**E27** 2 x Max 16W LED or  
2 x Max 21W fluo or  
2 x Max 70W halo

CE IP20 +LED

## COLOURS

white tobacco

sand

## FINISH

chrome

gold

## Crystal spotlight

design Manuel Vivian

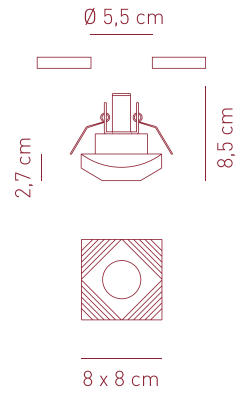

Crystal recessed downlight with metal finish.  
Light source with 12V GY6.35, GU4 fitting, or G9 fitting.  
*Faretto ad incasso in cristallo. Sorgente luminosa con attacco GY6.35 o GU4 a 12V oppure con attacco G9.*

### FA MENCAR

### COLOUR

Source:  
**G9** 1 x Max 40W halo 220-240VAC  crystal  
CE IP20

Source:  
**GY6.35** 1 x Max 35W 12VAC or  
**GU4** 1 x Max 35W 12VAC dicr.

CE IP20  with dedicated PSU

for transformer and dimming technology, please refer to our Axo Light pricelist or contact our representatives

hole  $\varnothing$  5.5 cm  
min depth 10 cm

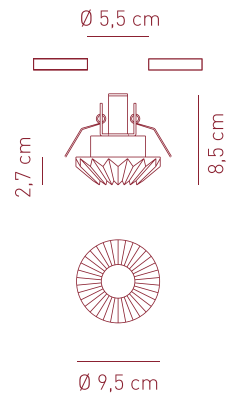

### FA NASHIR

### COLOUR

Source:  
**G9** 1 x Max 40W halo 220-240VAC  crystal  
CE IP20

Source:  
**GY6.35** 1 x Max 35W 12VAC or  
**GU4** 1 x Max 35W 12VAC dicr.

CE IP20  with dedicated PSU

for transformer and dimming technology, please refer to our Axo Light pricelist or contact our representatives

hole  $\varnothing$  5.5 cm  
min depth 10 cm

## Euler

design Cambi - Scatena - Turini

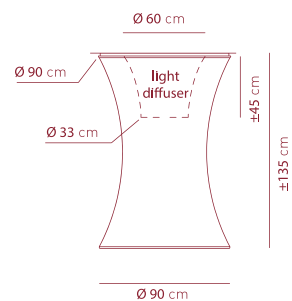

Collection of ceiling lamps made in white stretch fabric.  
*Collezione di lampade da soffitto in tessuto elastico bianco.*

**COMPOSITION/COMPOSIZIONE**  
Synthetic fabric / Polyamide 92% + Elastan 8%  
*Tessuto sintetico / Poliammide 92% + Elastan 8%*  
Colore / Colour Pantone star white 11-4202 TPX  
Glow Wire test (EN 60598-1): 750°C

**WEIGHT/PESO**  
70 gr/m<sup>2</sup>

### PL EULER P

### COLOUR

Source:  
**FLUO** GX24q-4 4 x 42W  
CE IP20 

 white

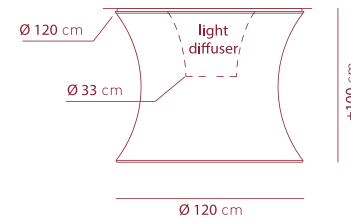

### PL EULER M

### COLOUR

Source:  
**FLUO** GX24q-4 4 x 42W  
CE IP20 

 white

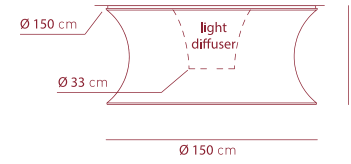

### PL EULER G

### COLOUR

Source:  
**FLUO** GX24q-4 4 x 42W  
CE IP20 

 white

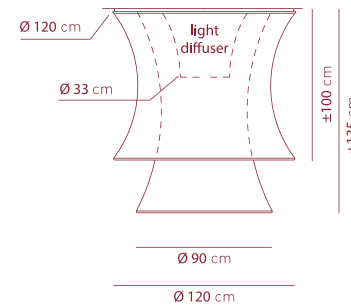

### PL EULER MP

### COLOUR

Source:  
**FLUO** GX24q-4 4 x 42W  
CE IP20 

 white

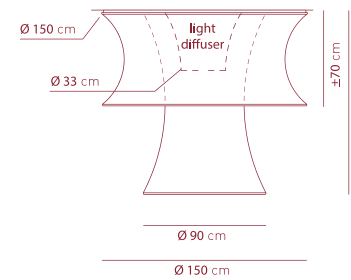

### PL EULER GP

### COLOUR

Source:  
**FLUO** GX24q-4 4 x 42W  
CE IP20 

 white

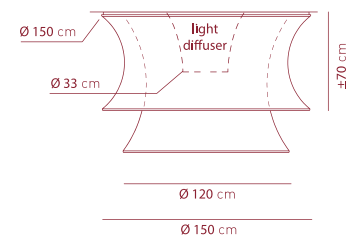

### PL EULER GM

### COLOUR

Source:  
**FLUO** GX24q-4 4 x 42W  
CE IP20 

 white

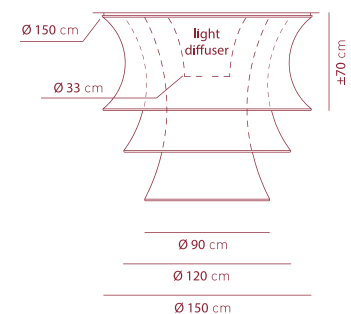

### PL EULER GMP

### COLOUR

Source:  
**FLUO** GX24q-4 4 x 42W  
CE IP20 

 white



# Explo

design Manuel Vivian

Collection of suspended lamps with painted metal and steel frame and with hand-made Murano glass bars. Light source with R7s fitting. Customised compositions are possible upon request.  
*Collezione di lampade a sospensione con montatura verniciata e acciaio, con barre in vetro di Murano lavorate a mano. Sorgente luminosa con attacco R7s. Possibilità di composizioni personalizzate.*

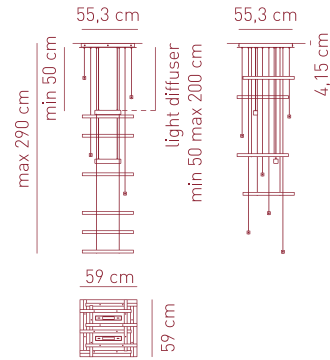

**SP EXP Q10**  
**Source:**  
**R7S** 2 x Max 120W (118)  
**CE** **IP20**

**COLOURS**  
 ○ white ● red  
**FINISH**  
 white and steel

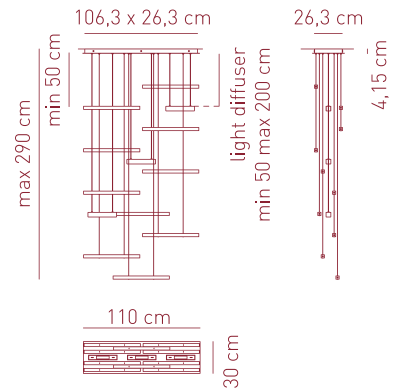

**SP EXPL 10**  
**Source:**  
**R7S** 3 x Max 120W (118)  
**CE** **IP20**

**COLOURS**  
 ○ white ● red  
**FINISH**  
 white and steel

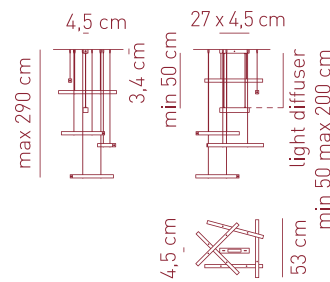

**SP EXPLO 5**  
**Source:**  
**R7S** 1 x Max 120W (118)  
**CE** **IP20**

**COLOURS**  
 ○ white ● red  
**FINISH**  
 white and steel

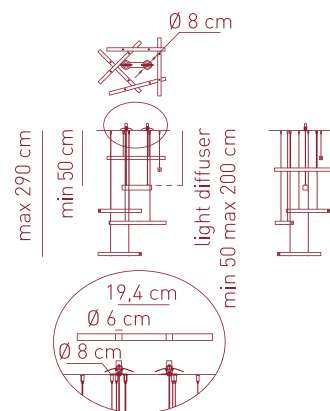

**SP EXPL I 5**  
**Source:**  
**R7S** 1 x Max 120W (118)  
**CE** **IP20**  
 hole Ø 6 cm  
 min depth 10 cm

**COLOURS**  
 ○ white ● red  
**FINISH**  
 white and steel

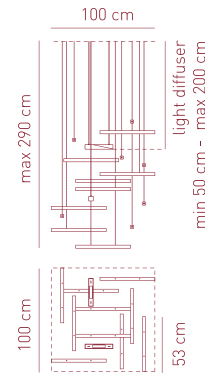

**SP EXPL I 5**  
**100X100 COMPOSITION**  
**customised composition example**  
**15 glass bars & 2 light diffusers**  
**Source:**  
**R7S** 2 x Max 120W (118)  
**CE** **IP20**

hole Ø 6 cm  
 min depth 10 cm

**COLOURS**  
 ○ white ● red  
**FINISH**  
 white and steel

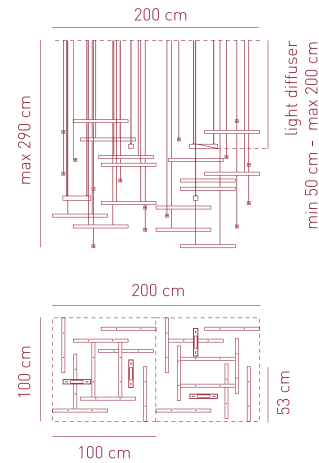

**SP EXPL I 5**  
**200X100 COMPOSITION**  
**customised composition example**  
**30 glass bars & 4 light diffusers**  
**Source:**  
**R7S** 4 x Max 120W (118)  
**CE** **IP20**

hole Ø 6 cm  
 min depth 10 cm

**COLOURS**  
 ○ white ● red  
**FINISH**  
 white and steel

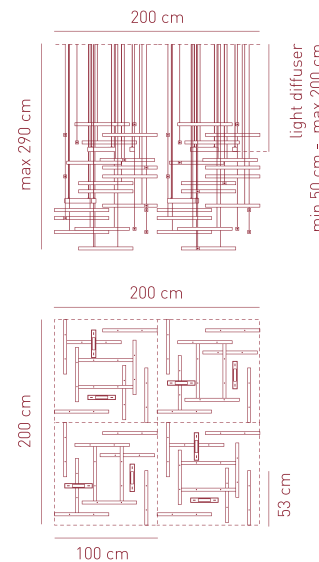

**SP EXPL I 5**  
**200X200 COMPOSITION**  
**customised composition example**  
**60 glass bars & 8 light diffusers**  
**Source:**  
**R7S** 8 x Max 120W (118)  
**CE** **IP20**

hole Ø 6 cm  
 min depth 10 cm

**COLOURS**  
 ○ white ● red  
**FINISH**  
 white and steel

## Fairy

design Manuel Vivian

Collection consisting of recessed downlights, wall lamps, ceiling lamps and suspended lamps with chromed metal frame and glass diffuser.  
*Collezione composta da faretti, lampade da parete, lampade da soffitto e lampade a sospensione con struttura in metallo e diffusore in cristallo.*

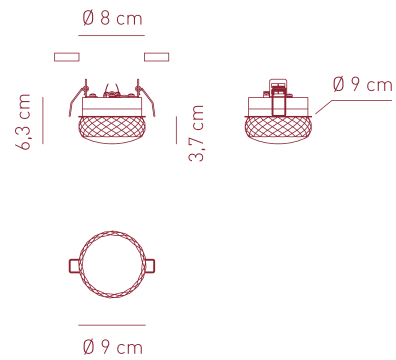

### FA FAIRY

**Source:**  
**LED** 6,2W - 350mA - diffused beam  
 - 2700K  
 CRI 90 - ~478 lm - 77 lm/W



hole  $\varnothing$  5.5 cm /  
 min depth 10 cm

### DIFFUSER COLOURS



### FINISH

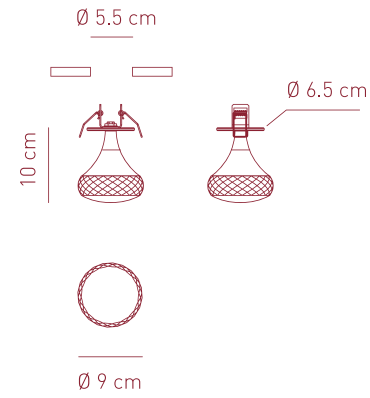
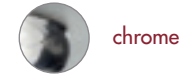

### PL FAIRY I recessed

**Source:**  
**LED** 6,2W - 350mA - diffused beam  
 - 2700K  
 CRI 90 - ~478 lm - 77 lm/W



driver not included

for drivers and dimming technology,  
 please refer to our Axo Light pricelist  
 or contact our representatives

hole  $\varnothing$  5.5 cm  
 min depth 10 cm

### DIFFUSER COLOURS



### FINISH

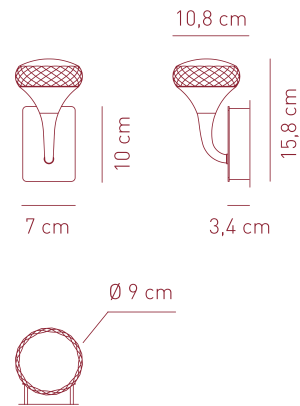

### AP FAIRY

**Source:**  
**LED** 6,2W - diffused beam - 2700K  
 CRI 90 - ~478 lm - 77 lm/W



### DIFFUSER COLOURS



### FINISH

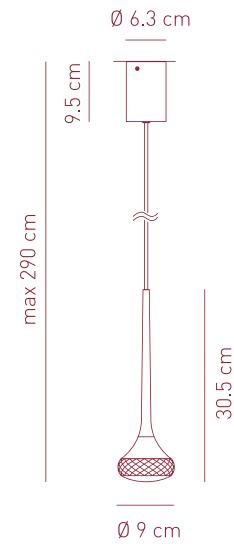
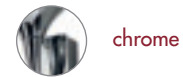

### SP FAIRY

**Source:**  
**LED** 6,2W - diffused beam - 2700K  
 CRI 90 - ~478 lm - 77 lm/W



### DIFFUSER COLOURS

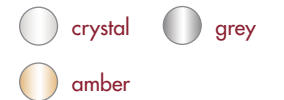

### FINISH

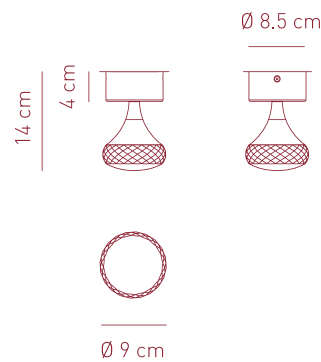
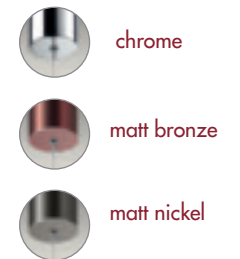

### PL FAIRY

**Source:**  
**LED** 6,2W - diffused beam - 2700K  
 CRI 90 - ~478 lm - 77 lm/W



### DIFFUSER COLOURS

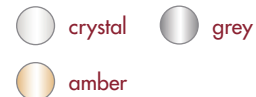

### FINISH

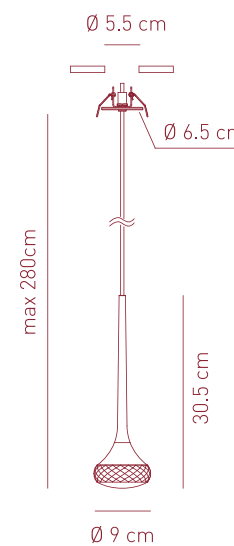

### SP FAIRY I

**Source:**  
**LED** 6,2W - 350mA - diffused beam  
 - 2700K  
 CRI 90 - ~478 lm - 77 lm/W



driver not included

for drivers and dimming technology,  
 please refer to our Axo Light pricelist  
 or contact our representatives

hole  $\varnothing$  5.5 cm  
 min depth 10 cm

### DIFFUSER COLOURS



### FINISH





## Fairy

design Manuel Vivian

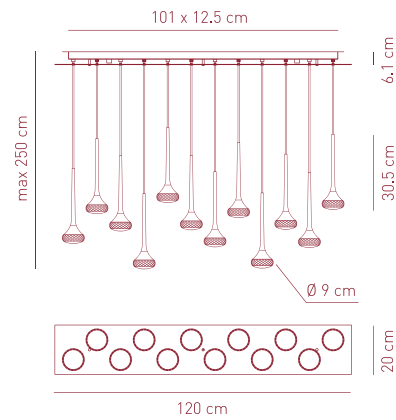

Collection consisting of recessed downlights, wall lamps, ceiling lamps and suspended lamps with chromed metal frame and glass diffuser.  
*Collezione composta da faretti, lampade da parete, lampade da soffitto e lampade a sospensione con struttura in metallo e diffusore in cristallo.*

### SP FAI 12 R

**Source:**  
**LED** 12 x 6,2W - diffused beam - 2700K  
 CRI 90 - 12x ~478 lm - 77 lm/W



### DIFFUSER COLOURS

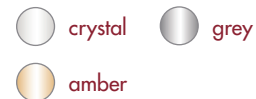

### FINISH

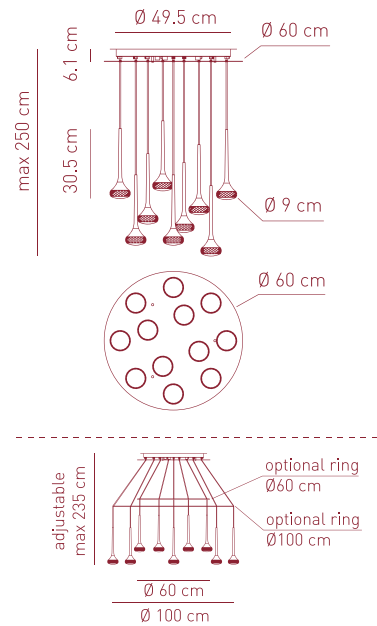
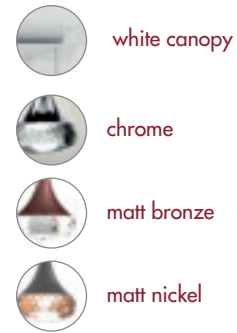

### SP FAIR 12

**Source:**  
**LED** 12 x 6,2W - diffused beam - 2700K  
 CRI 90 - 12x ~478 lm - 77 lm/W



### DIFFUSER COLOURS



### FINISH

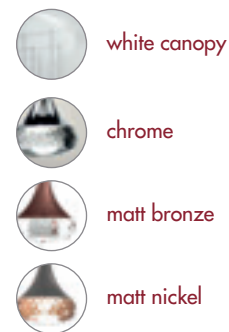

Ring for customised composition optional

We suggest the use of both the Ø 60 cm and Ø 100 cm rings together when creating customised compositions

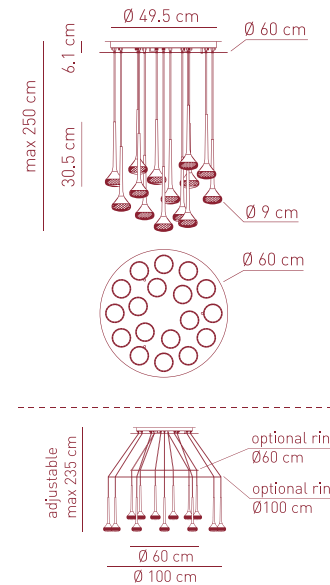

### SP FAIRY 18

**Source:**  
**LED** 18 x 6,2W - diffused beam  
 - 2700K  
 CRI 90 - 18 x ~478 lm - 77 lm/W

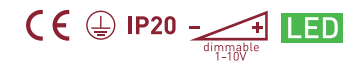

### DIFFUSER COLOURS



### FINISH



Ring for customised composition optional

We suggest the use of both the Ø 60 cm and Ø 100 cm rings together when creating customised compositions

## Favilla

design Manuel Vivian

Collection consisting of adjustable wall or ceiling lamps in aluminium, also in a recessed version.  
*Collezione composta da lampada da parete o da soffitto in alluminio in vari colori, orientabile. Disponibile anche nella versione ad incasso.*

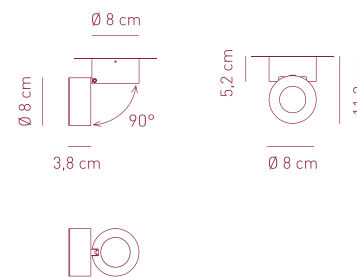

### FAVILLA WALL/CEILING/SPOT

**Source:**  
**LED**  
 22° or 45° beam

6,2W: CRI 90 - ~437 lm - 70 lm/W - 2700K

8,4W: CRI 80 - ~594 lm - 70 lm/W - 4000K



### COLOURS

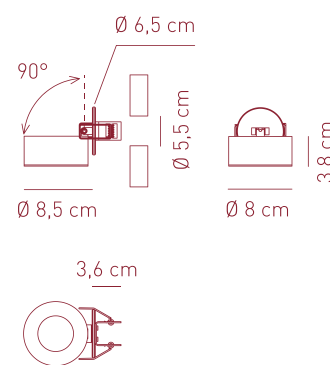

### FAVILLA RECESSED

**Source:**  
**LED**  
 350mA - 22° or 45° beam

6,2W: CRI 90 - ~437 lm - 70 lm/W - 2700K



driver not included

for drivers and dimming technology, please refer to our Axo Light pricelist or contact our representatives

hole Ø 5.5 cm  
 min depth 10 cm

### COLOURS



# Fedora

design Dima Loginoff

Collection consisting of recessed downlight and suspended lamps.  
Collezione composta da faretto ad incasso e lampade a sospensione.

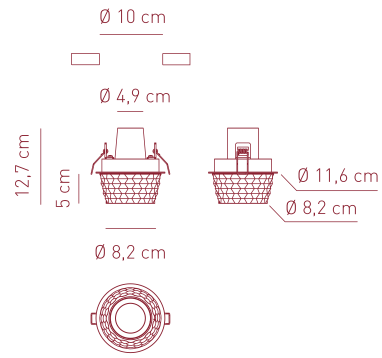

## FA FEDORA

Source:  
GU10 LED 1 x Max 7,5W  
only LED bulb 220-240VAC

CE IP20 LED

hole Ø 10 cm  
min depth 10 cm

## COLOURS



glass

## FINISH



white varnished metal

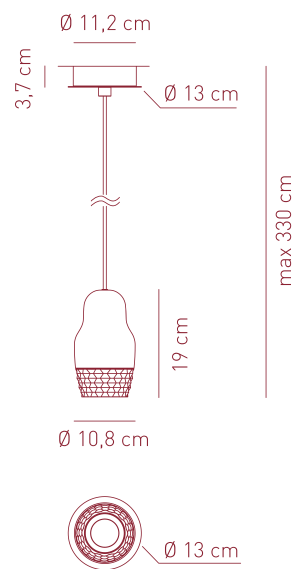

## SP FEDOR 1

Source:  
GU10 LED 1 x Max 7,5W  
only LED bulb 220-240VAC

CE IP20 LED

hole Ø 10 cm  
min depth 10 cm

## COLOURS



rose gold+glass



bronze+glass



chrome+glass

## FINISH



white varnished metal

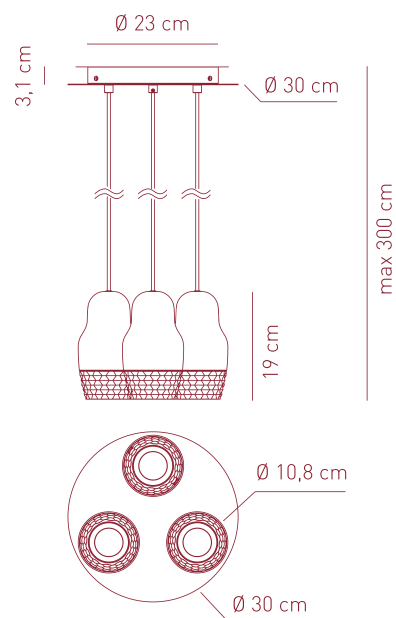

## SP FEDOR 3

Source:  
GU10 LED 3 x Max 7,5W  
only LED bulbs 220-240VAC

CE IP20 LED

## COLOURS



rose gold+glass



bronze+glass



chrome+glass

## FINISH



white varnished metal

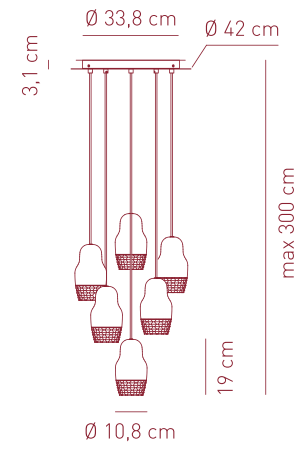

## SP FEDOR 6

Source:  
GU10 LED 6 x Max 7,5W  
only LED bulbs 220-240VAC

CE IP20 LED

## COLOURS



rose gold+glass



bronze+glass



chrome+glass

## FINISH



white varnished metal

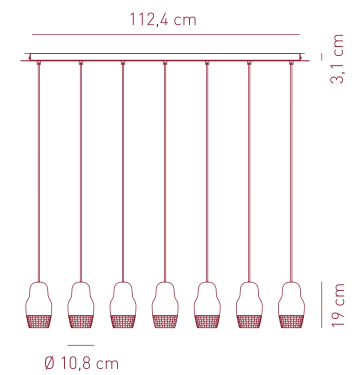
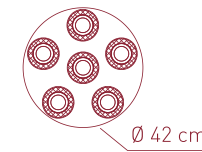

## SP FEDOR 7

Source:  
GU10 LED 7 x Max 7,5W  
only LED bulbs 220-240VAC

CE IP20 LED

## COLOURS



rose gold+glass



bronze+glass



chrome+glass

## FINISH



white varnished metal

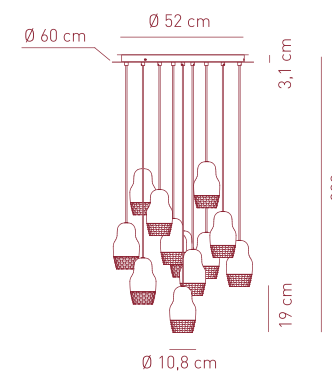
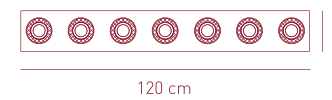

## SP FEDO 12

Source:  
GU10 LED 12 x Max 7,5W  
only LED bulbs 220-240VAC

CE IP20 LED

## COLOURS



rose gold+glass



bronze+glass



chrome+glass

## FINISH



white varnished metal

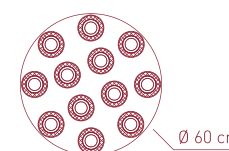



# Framework LED

design Manuel Vivian



Collection consisting of ceiling or wall lamps and suspended lamps in white aluminium. Available in several sizes. The ceiling/wall lamps are also supplied in three different heights. Built-in LED light source.

Collezione di lampade da soffitto o da parete e lampade a sospensione in alluminio bianco. Disponibile in varie dimensioni. Le lampade da soffitto/da parete sono fornite in tre diverse altezze. Sorgente luminosa a LED integrato dimmerabile.

## FINISH/FINITURA

Wrinkled-white aluminium

Alluminio verniciato bianco raggrinzato

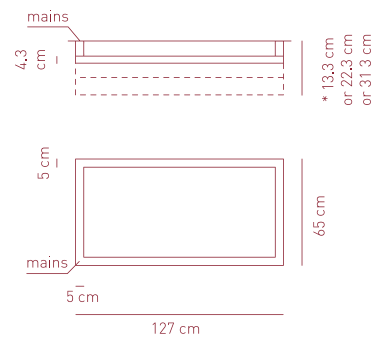

**PL FW P 090/180/270**  
application: both as ceiling or wall lamp

## COLOUR

wrinkled white aluminium

## Source:

**LED** 65,6W - diffused beam - 3000K  
CRI 80 - ~8824 lm - 134,5 lm/W

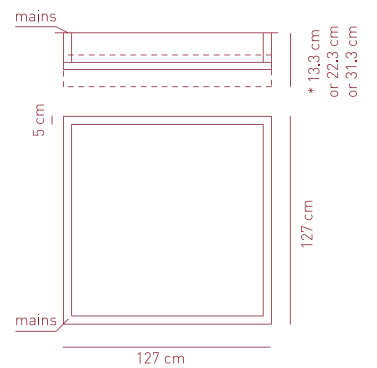

**PL FW M 090/180/270**  
application: both as ceiling or wall lamp

## COLOUR

wrinkled white aluminium

## Source:

**LED** 65,6W - diffused beam - 3000K  
CRI 80 - ~8824 lm - 134,5 lm/W

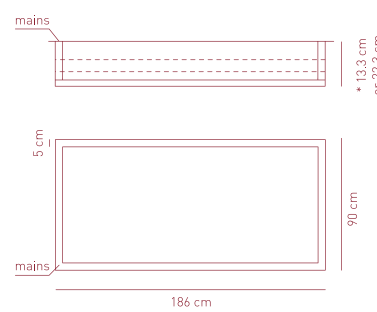

**PL FW G 090/180/270**  
application: both as ceiling or wall lamp

## COLOUR

wrinkled white aluminium

## Source:

**LED** 98,4W - diffused beam - 3000K  
CRI 80 - ~13236 lm - 131 lm/W

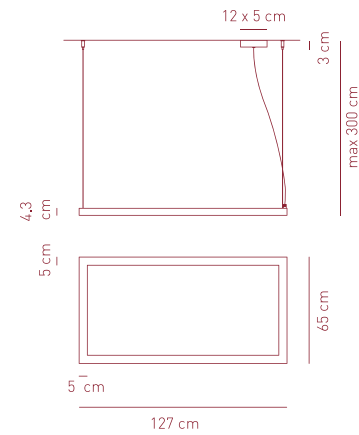

## SP FRAME P

## Source:

**LED** 65,6W - diffused beam - 3000K  
CRI 80 - ~8824 lm - 134,5 lm/W

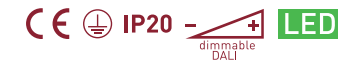

## COLOUR

wrinkled white aluminium

white canopy

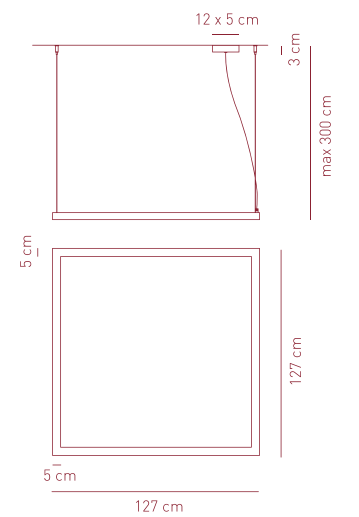

## SP FRAME M

## Source:

**LED** 65,6W - diffused beam - 3000K  
CRI 80 - ~8824 lm - 134,5 lm/W



## COLOUR

wrinkled white aluminium

white canopy

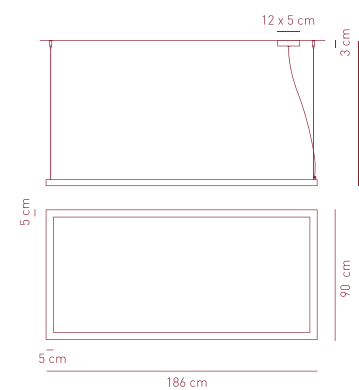

## SP FRAME G

## Source:

**LED** 98,4W - diffused beam - 3000K  
CRI 80 - ~13236 lm - 131 lm/W



## COLOUR

wrinkled white aluminium

white canopy

## \*Available heights



PL FW P/M/G 090



PL FW P/M/G 180



PL FW P/M/G 270



diffuser

# Hoops

design Giovanni Barbato

Collection consisting of ceiling lamps and suspended lamps with interchangeable elements in different shapes and sizes. Gold finish. Built-in dimmable LED light source. The suspended lamps can light upward and downward.

Collezione composta da lampade da soffitto e lampade a sospensione con elementi intercambiabili di diverse forme e dimensioni. Finitura dorata. Sorgente luminosa a LED integrato dimmerabile. Le lampade a sospensione prevedono un'illuminazione uplight e downlight.

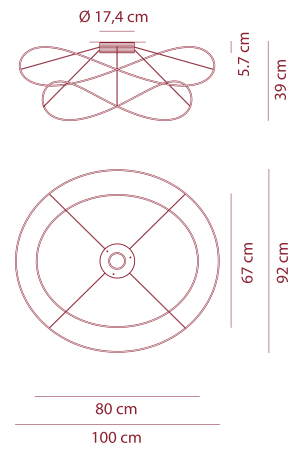

## PL HOOPS 2

Source:

**LED** 16,6W - diffused beam - 3000K  
CRI 90 - ~1210 lm - 73 lm/W



COLOUR

gold

FINISH

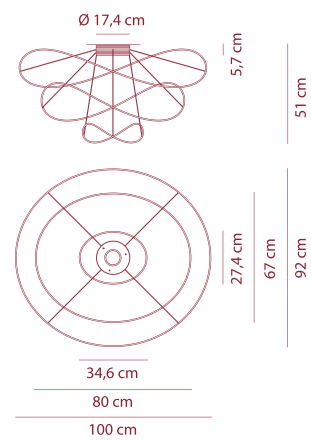

## PL HOOPS 3

Source:

**LED** 16,6W - diffused beam - 3000K  
CRI 90 - ~1210 lm - 73 lm/W



COLOUR

gold

FINISH

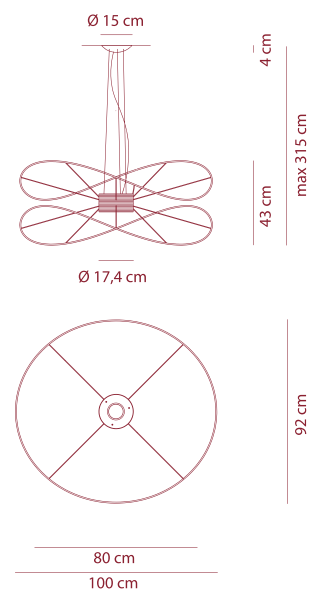

## SP HOOPS 2 with upward & downward light

Source:

**LED** 33,2W - diffused beam - 3000K  
CRI 90 - ~2420 lm - 73 lm/W



COLOUR

gold

FINISH

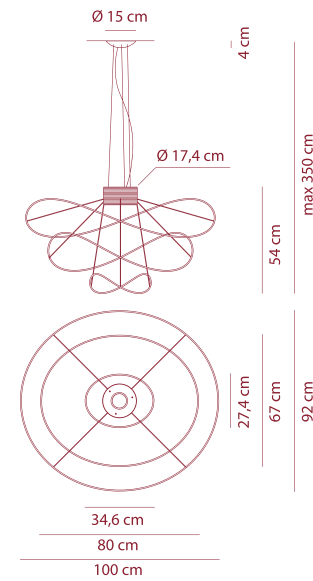

## SP HOOPS 3 with upward & downward light

Source:

**LED** 33,2W - diffused beam - 3000K  
CRI 90 - ~2420 lm - 73 lm/W



COLOUR

gold

FINISH

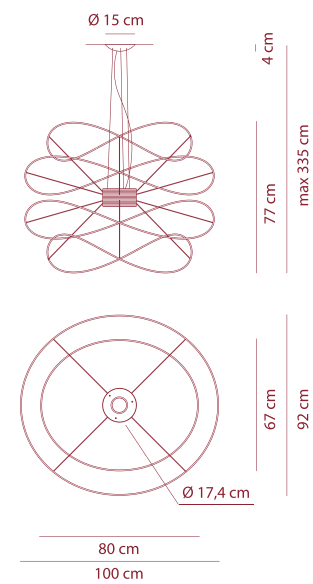

## SP HOOPS 4 with upward & downward light

Source:

**LED** 33,2W - diffused beam - 3000K  
CRI 90 - ~2420 lm - 73 lm/W



COLOUR

gold

FINISH

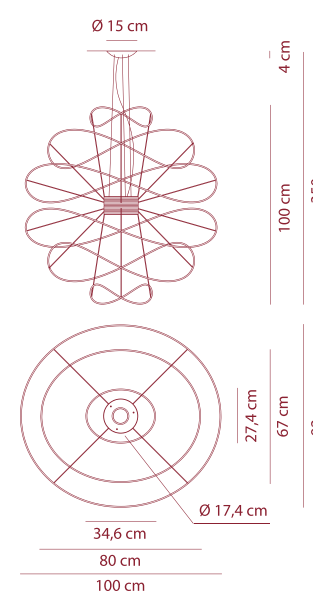

## SP HOOPS 6 with upward & downward light

Source:

**LED** 33,2W - diffused beam - 3000K  
CRI 90 - ~2420 lm - 73 lm/W



COLOUR

gold

FINISH





## Layers

design Vanessa Vivian



Collection consisting of suspended lamps with a metal frame covered with strips of extra smooth flame-retardant pongé fabric. Available in several colours and sizes. Screw fitting light source.

Collezione di lampade a sospensione con struttura metallica rivestita con fettuccia di tessuto ignifugato pongé superliscio. Disponibile vari colori e dimensioni. Sorgente luminosa con attacco a vite.

### COMPOSIZIONE/COMPOSITION

Extra smooth flame retardant pongé fabric - 100% polyester

Tessuto ignifugato pongé superliscio - 100% poliestere

Glow Wire Test (EN 60598-1): 960°C

### PESO/WEIGHT

55 ± 5% gr/m<sup>2</sup>

### AVAILABLE UPON REQUEST

- orange
- warm white
- gold yellow
- light grey
- dark grey
- brick red
- burgundy
- red
- light green
- Multicolor 1: burgundy + red + orange + yellow
- Multicolor 2: dark grey + light grey + white

### SP LAY A

**Source:**  
**E27** 9 x Max 16W LED or  
 9 x Max 20W fluo or  
 9 x Max 70W halo

**CE** **IP20 +LED**

### COLOUR

white

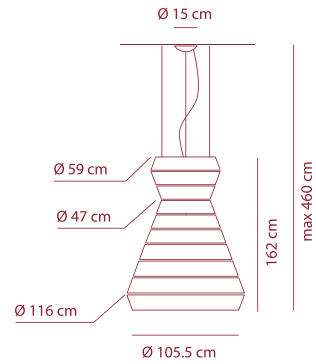

### SP LAY B

**Source:**  
**E27** 15 x Max 16W LED or  
 15 x Max 20W fluo or  
 15 x Max 70W halo

**CE** **IP20 +LED**

### COLOUR

white

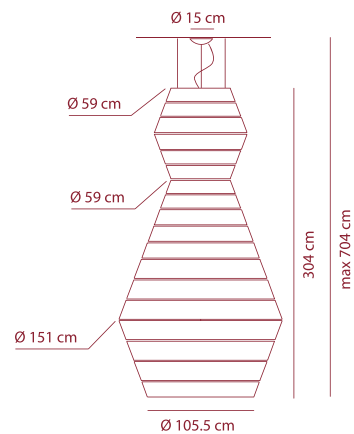

### SP LAY C

**Source:**  
**E27** 15 x Max 16W LED or  
 15 x Max 20W fluo or  
 15 x Max 70W halo

**CE** **IP20 +LED**

### COLOUR

white

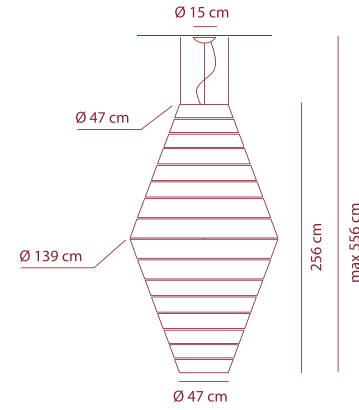

### SP LAY D

**Source:**  
**E27** 9 x Max 16W LED or  
 9 x Max 20W fluo or  
 9 x Max 70W halo

**CE** **IP20 +LED**

### COLOUR

white

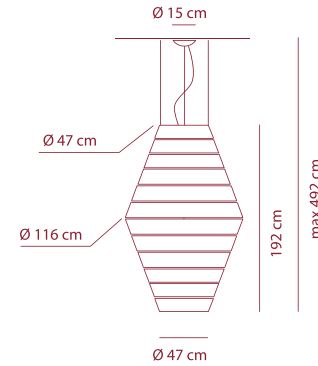

### SP LAY E

**Source:**  
**E27** 9 x Max 16W LED or  
 9 x Max 20W fluo or  
 9 x Max 70W halo

**CE** **IP20 +LED**

### COLOUR

white

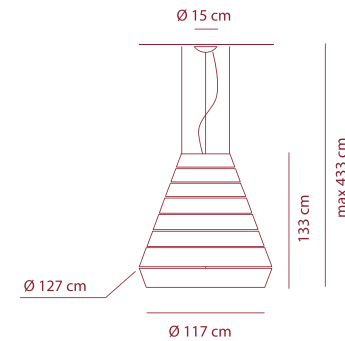

### SP LAY F

**Source:**  
**E27** 9 x Max 16W LED or  
 9 x Max 20W fluo or  
 9 x Max 70W halo

**CE** **IP20 +LED**

### COLOUR

white

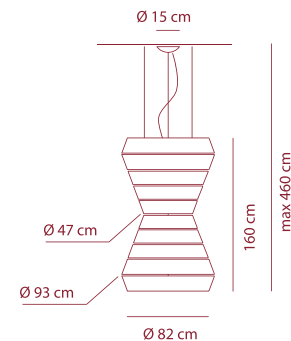

## Lik

design Serge & Robert Cornelissen

Collection of aluminium wall lamps. Built-in dimmable LED light.  
Lampada da parete in alluminio. Sorgente luminosa a LED integrato dimmerabile.

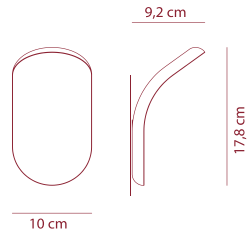

### AP LIK

**Source:**  
**LED** 16,6W - 3000K  
CRI 90 - ~1350 lm - 81 lm/W

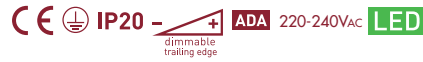

### COLOURS

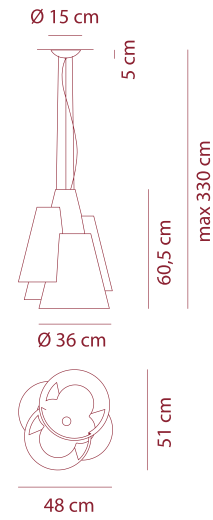

### SP MELT 60

**Source:**  
**E27** 1 x Max 16W LED or  
1 x Max 23W fluo or  
1 x Max 70W halo



Diffuser not included (optional)

### COLOURS

light patterns:

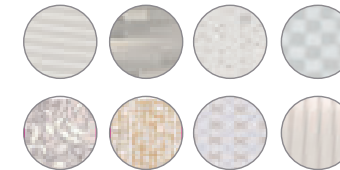

### FINISH



dark patterns:



**BC**  
light patterns outside/  
white inside



**NA**  
dark patterns outside/  
silver inside



**BA**  
light patterns outside/  
silver inside



**NE**  
dark patterns outside/  
gold inside



**BO**  
light patterns outside/  
gold inside

## Melting Pot

design Sandro Santantonio

Collection consisting of wall lamps, suspended lamps and floor lamps.  
The lampshades coming in various decorative patterns.  
Opalescent diffusers available on request. Screw fitting light source.  
Collezione composta da lampade da parete, a sospensione e da terra.  
I paralumi sono proposti con diversi pattern decorativi. Diffusori opalescenti disponibili su richiesta. Sorgente luminosa con attacco a vite.

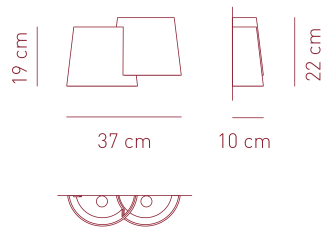

### AP MELTIN

**Source:**  
**E27** 2 x Max 16W LED or  
2 x Max 15W fluo or  
2 x Max 30W halo



### COLOURS



light patterns:

### FINISH



white varnished metal



**BC**  
light patterns outside/  
white inside



dark patterns:



**NE**  
dark patterns outside/  
gold inside



**BO**  
light patterns outside/  
gold inside

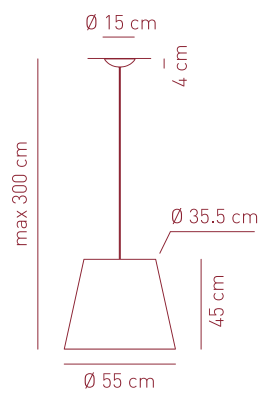

### SP MELT 55

**Source:**  
**E27** 3 x Max 16W LED or  
3 x Max 15W fluo or  
3 x Max 70W halo



Diffuser not included (optional)

### COLOURS



light patterns:

### FINISH



white canopy



**BA**  
light patterns outside/  
silver inside



dark patterns:



**NA**  
dark patterns outside/  
silver inside



**BO**  
light patterns outside/  
gold inside

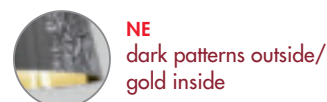

**NE**  
dark patterns outside/  
gold inside

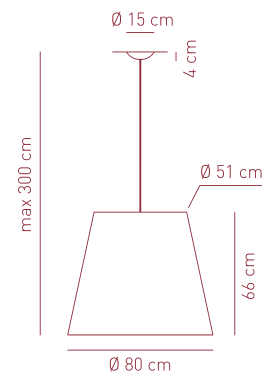

### SP MELT 80

**Source:**  
**E27** 3 x Max 16W LED or  
3 x Max 15W fluo or  
3 x Max 70W halo



Diffuser not included (optional)

### COLOURS



light patterns:



**BA**  
light patterns outside/  
silver inside



**BO**  
light patterns outside/  
gold inside

### FINISH



dark patterns:



**NA**  
dark patterns outside/  
silver inside

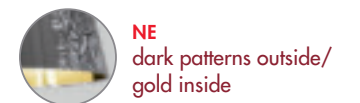

**NE**  
dark patterns outside/  
gold inside



# Melting Pot

design Sandro Santantonio

Collection consisting of wall lamps, suspended lamps and floor lamps.  
The lampshades coming in various decorative patterns.  
Opalescent diffusers available on request.  
Screw fitting light source.

Collezione composta da lampade da parete, a sospensione e da terra.  
I paralumi sono proposti con diversi pattern decorativi.  
Diffusori opalescenti disponibili su richiesta.  
Sorgente luminosa con attacco a vite.

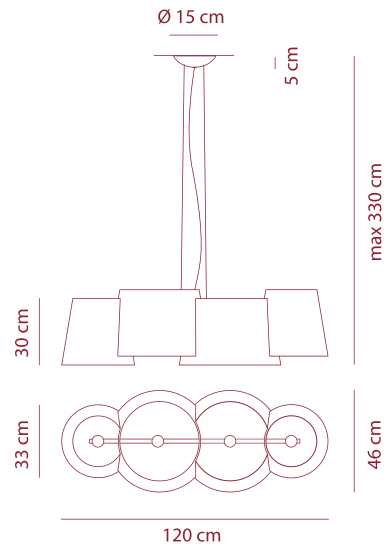

## SP MEL 115

**Source:**  
**E27** 4 x Max 16W LED or  
4 x Max 23W fluo or  
4 x Max 70W halo

**CE** **IP20 +LED**

Diffuser not included (optional)

## COLOURS

light patterns:

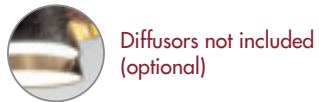
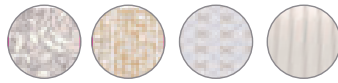

Diffusers not included (optional)

## FINISH



dark patterns:

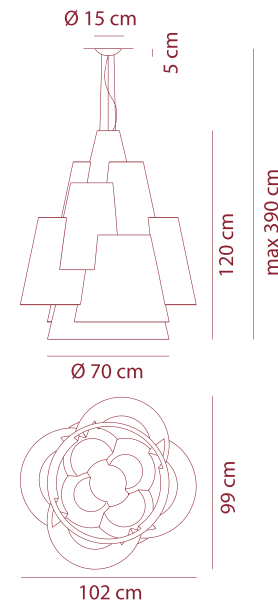
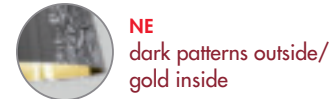

## SP MEL 120

**Source:**  
**E27** 3 x Max 16W LED or  
3 x Max 23W fluo or  
3 x Max 70W halo

**CE** **IP20 +LED**

Diffuser not included (optional)

## COLOURS

light patterns:

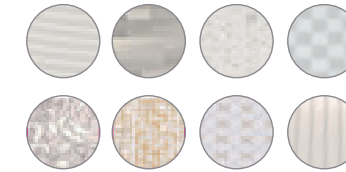

Diffusers not included (optional)

## FINISH



dark patterns:

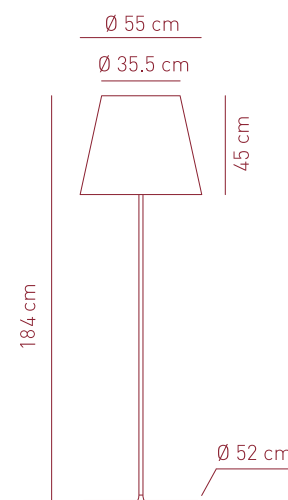

## PT MELT 55

**Source:**  
**E27** 3 x Max 16W LED or  
3 x Max 15W fluo or  
3 x Max 70W halo

(Dimmable lamps required)

**CE** **IP20 - dimmable +LED**

## COLOURS



## FINISH



## Meling Pot

design Sandro Santantonio

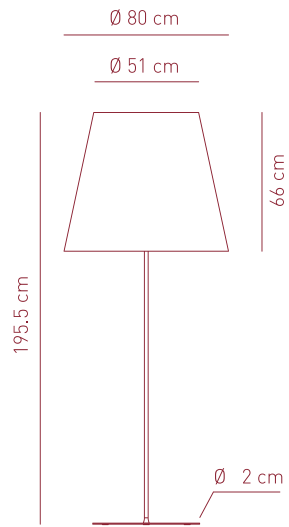

Collection consisting of wall lamps, suspended lamps and floor lamps. The lampshades coming in various decorative patterns. Opalescent diffusers available on request. Screw fitting light source.  
 Collezione composta da lampade da parete, a sospensione e da terra. I paralumi sono proposti con diversi pattern decorativi. Diffusori opalescenti disponibili su richiesta. Sorgente luminosa con attacco a vite.

### PT MELT 80

**Source:**  
**E27** 3 x Max 16W LED or  
 3 x Max 15W fluo or  
 3 x Max 70W halo

CE IP20 +LED

### FINISH



### COLOURS



light patterns:



**BA**  
 light patterns outside/  
 silver inside

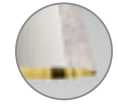

**BO**  
 light patterns outside/  
 gold inside



dark patterns:

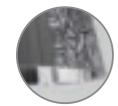

**NA**  
 dark patterns outside/  
 silver inside

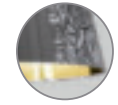

**NE**  
 dark patterns outside/  
 gold inside

## Momus Mini

design Manuel Vivian

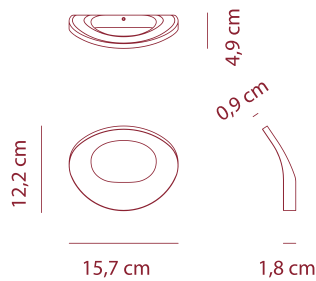

Wall lamp in white aluminium. Built-in LED light source.  
 Lampada da parete in alluminio bianco. Sorgente luminosa a LED integrato.

### MOMUS MINI WALL

**Source:**  
**LED** 3W - diffused beam - 3000K  
 CRI 85 - 160 lm - 53 lm/W

CE IP20

driver included

### COLOUR



## Mountain View

design Dima Loginoff

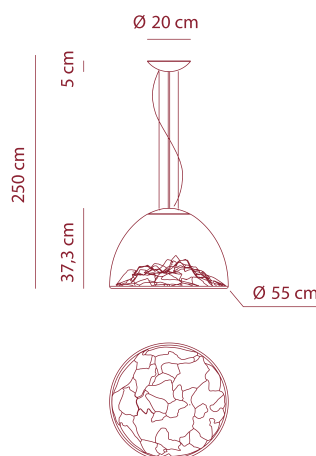

Suspended lamp made of transparent blown glass.  
 Lampada a sospensione realizzata in vetro soffiato trasparente.

### SP MOUNTA

**Source:**  
**LED** 16W - 3000K  
 CRI 80 - ~1345 lm - 84 lm/W

CE IP20

### COLOURS

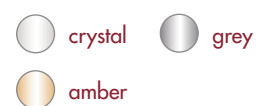

### FINISH

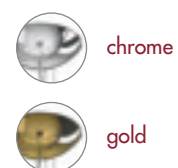

## Muse

design Sandro Santantonio

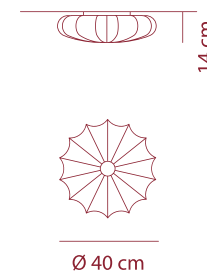

Collection consisting of ceiling, wall, suspended and table lamps with metal frame and removable, washable elastic fabric covering.  
 Collezione composta da lampade da soffitto, da parete, a sospensione e da tavolo con struttura metallica e rivestimento in tessuto elasticizzato, sfoderabile e lavabile.

### PL MUSE 40

application: both as ceiling or wall lamp

**Source:**  
**E27** 1 x Max 6,5W LED or  
 1 x Max 42W halo

CE IP20 +LED

### COLOURS

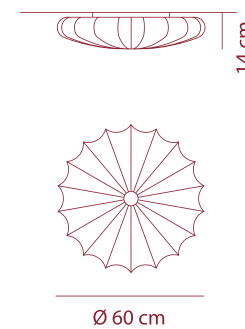

### PL MUSE 60

application: both as ceiling or wall lamp

**Source:**  
**E27** 2 x Max 6,5W LED or  
 2 x Max 42W halo

CE IP20 +LED

### COLOURS

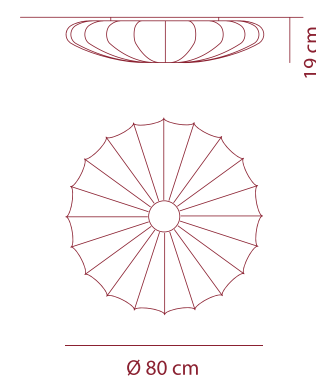

### PL MUSE 80

application: both as ceiling or wall lamp

**Source:**  
**E27** 3 x Max 16W LED or  
 3 x Max 70W halo

CE IP20 +LED

Diffuser kit only for E27 when mounting LED or fluo bulb (optional)

### COLOURS





# Muse

design Sandro Santantonio

Collection consisting of ceiling, wall, suspended and table lamps with metal frame and removable, washable elastic fabric covering.  
*Collezione composta da lampade da soffitto, da parete, a sospensione e da tavolo con struttura metallica e rivestimento in tessuto elasticizzato, sfoderabile e lavabile.*

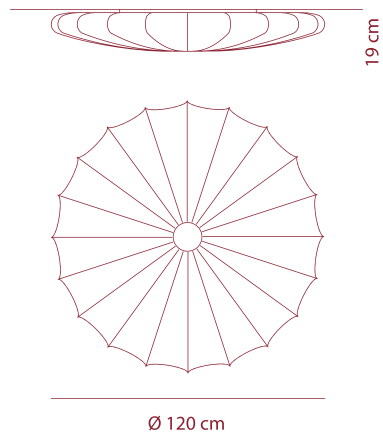

**PL MUS 120**  
**application: both as ceiling or wall lamp**

**Source:**  
**E27** 3 x Max 16W LED or  
 3 x Max 70W halo

CE IP20 +LED

Glass diffuser kit only for E27  
 when mounting LED  
 or fluo bulb (optional)

## COLOURS

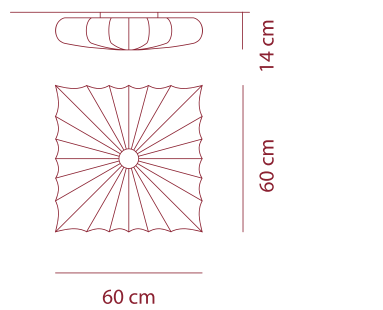

**PL MUS 60 Q**  
**application: both as ceiling or wall lamp**

**Source:**  
**E27** 2 x Max 6,5W LED or  
 2 x Max 42W halo

CE IP20 +LED

## COLOUR

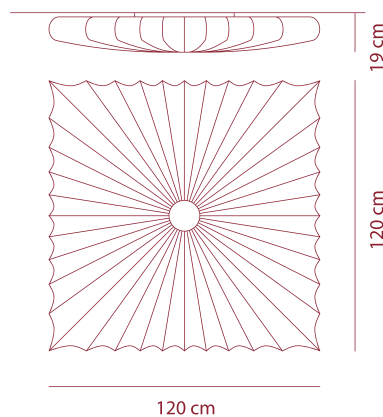

**PL MUS 120 Q**  
**application: both as ceiling or wall lamp**

**Source:**  
**E27** 3 x Max 16W LED or  
 3 x Max 70W halo

CE IP20 +LED

Glass diffuser kit only for E27  
 when mounting LED  
 or fluo bulb (optional)

## COLOUR

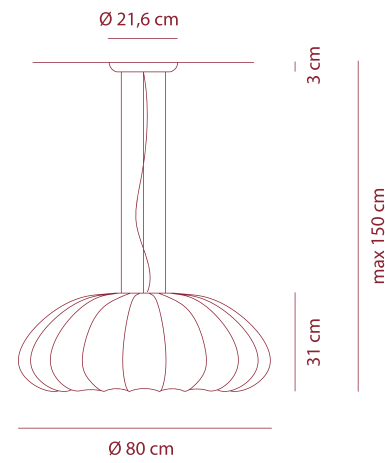

## SP MUSE

**Source:**  
**E27** 1 x Max 20W LED or  
 1 x Max 116W halo

CE IP20 +LED

## COLOURS



## FINISH

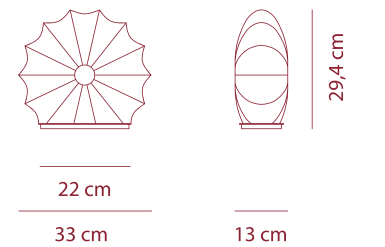

## LT MUSE P

**Source:**  
**E14** 1 x Max 6,5W LED or  
 1 x Max 42W halo

CE IP20 +LED

## COLOURS



## FINISH

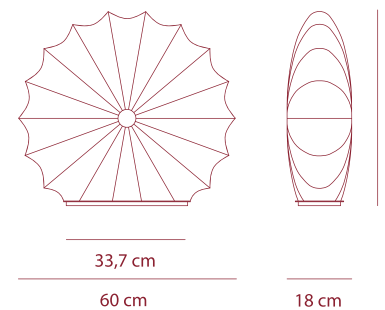

## LT MUSE G

**Source:**  
**E27** 1 x Max 20W LED or  
 1 x Max 105W halo  
 (dimming lamps required)

CE IP20 - dimmable +LED

## COLOURS



## FINISH



# Nafir

design Karim Rashid

Collection consisting of recessed downlights, ceiling lamps and suspended lamps in injection moulded ABS.  
*Collezione composta da faretti ad incasso, lampade da soffitto e lampade a sospensione in ABS ad iniezione.*

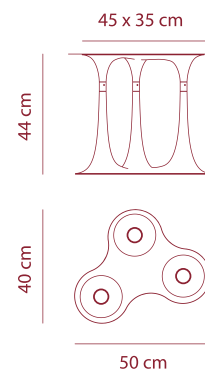

## PL NAFIR 3

**Source:**  
**GU10** LED 3 x Max 7,5W  
**only** LED bulb 220-240VAC

CE IP20 LED

## COLOURS



## Nafir

design Karim Rashid

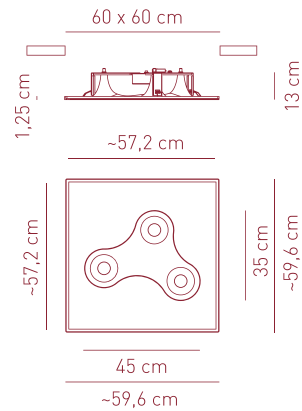

Collection consisting of recessed downlights, ceiling lamps and suspended lamps in injection moulded ABS.

Collezione composta da faretti ad incasso, lampade da soffitto e lampade a sospensione in ABS ad iniezione.

### PL NAFI 3

Source:  
**GU5.3** LED 3 x Max 5W  
- **only** LED bulbs 220-240VAc



### COLOURS

- white
- white/chrome
- white/gold

transformer included

hole 59,6 x 59,6 cm  
min depth: 15 cm (standard false ceiling) or  
or 40 cm (false ceiling tiles)

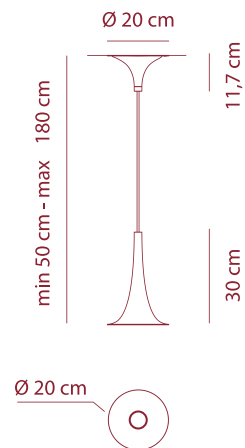

### SP NAFIR 1

Source:  
**GU10** LED 1 x Max 7,5W  
- **only** LED bulbs 220-240VAc



### COLOURS

- white
- white/chrome
- white/gold
- white/bronze
- white/pink gold

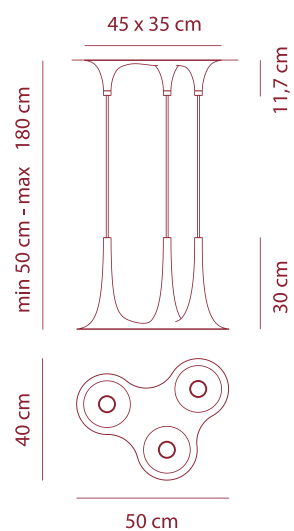

### SP NAFIR 3

Source:  
**GU10** LED 3 x Max 7,5W  
- **only** LED bulbs 220-240VAc



### COLOURS

- white
- white/chrome
- white/gold
- white/bronze
- white/pink gold

## Necky

design Diadora Design

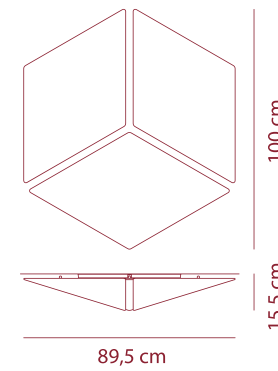

Ceiling or wall lamp with metal frame and white removable, washable elastic fabric covering. Screw fitting light source.

Lampada da parete o da soffitto con struttura metallica e rivestimento in tessuto bianco elasticizzato, sfoderabile e lavabile. Sorgente luminosa con attacco a vite.

**PL NEC 100**  
application: both as ceiling or wall lamp

### COLOURS

- white

Source:  
**E27** 3 x Max 6,5W LED or  
3 x Max 42W halo



## Nelly

design Manuel Vivian

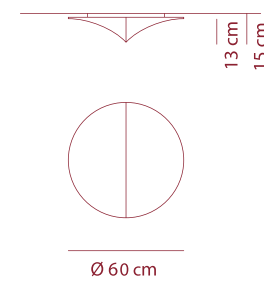

Collection consisting of ceiling or wall lamps with metal frame and removable, washable elastic fabric covering. Screw fitting light source.

Collezione di lampade da parete o da soffitto con struttura metallica e rivestimento in tessuto elasticizzato, sfoderabile e lavabile. Sorgente luminosa con attacco a vite.

**PL NELL 60**  
application: both as ceiling or wall lamp

### COLOURS

- white
- ivory pattern
- white pattern

Source:  
**E27** 2 x Max 16W LED or  
2 x Max 70W halo

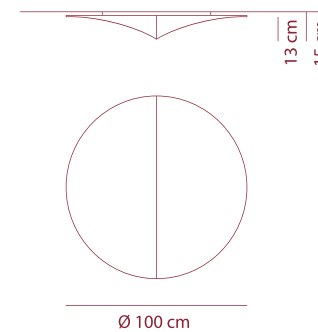

**PL NEL 100**  
application: both as ceiling or wall lamp

### COLOURS

- white
- ivory pattern
- white pattern

Source:  
**E27** 3 x Max 16W LED or  
3 x Max 70W halo

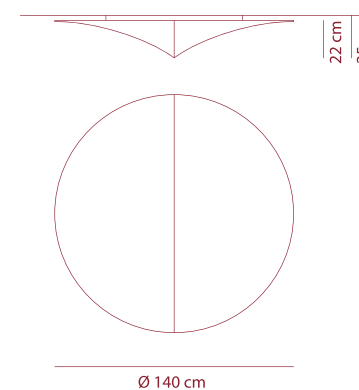

**PL NEL 140**  
application: both as ceiling or wall lamp

### COLOURS

- white
- ivory pattern
- white pattern

Source:  
**E27** 4 x Max 16W LED or  
4 x Max 70W halo





## Nelly Straight

design Manuel Vivian

Collection consisting of ceiling or wall lamps with metal frame and removable, washable elastic fabric covering.  
*Collezione di lampade da parete o da soffitto con struttura metallica e rivestimento in tessuto elasticizzato. Disponibile in vari colori e dimensioni.*

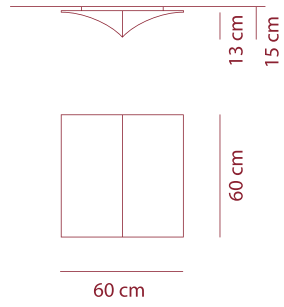

**PL NEL S 60**  
**application: both as ceiling or wall lamp**

**Source:**  
**E27** 2 x Max 16W LED or  
 2 x Max 70W halo

CE IP20 +LED

### COLOURS

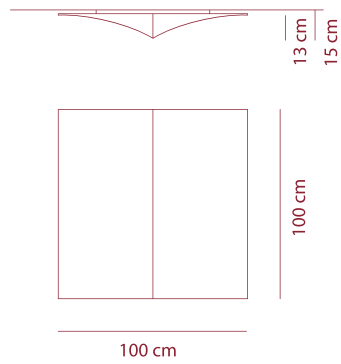

**PL NE S 100**  
**application: both as ceiling or wall lamp**

**Source:**  
**E27** 3 x Max 16W LED or  
 3 x Max 70W halo

CE IP20 +LED

### COLOURS

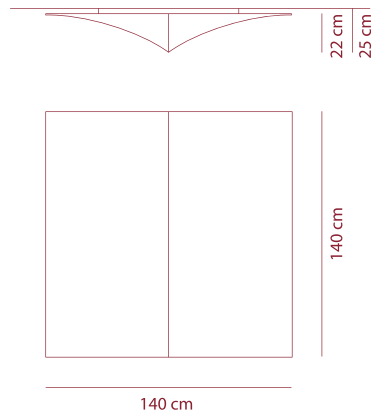

**PL NE S 140**  
**application: both as ceiling or wall lamp**

**Source:**  
**E27** 4 x Max 16W LED or  
 4 x Max 70W halo

CE IP20 +LED

### COLOURS



## Orchid

design Rainer Mutsch

Collection consisting of aluminium wall lamps, ceiling lamps, suspended lamps and floor lamps. Built-in dimmable LED light source.

*Collezione composta da lampade da parete, lampade da soffitto, lampade a sospensione e lampade da terra in alluminio. La sorgente luminosa è a LED integrato dimmerabile.*

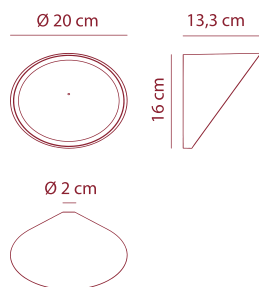

**AP ORCHID**  
**application: both as ceiling or wall lamp**

**Source:**  
**LED** 15W - diffused beam - 3000K  
 CRI 90 - ~882 lm - 59 lm/W

CE IP20 +LED

### COLOURS

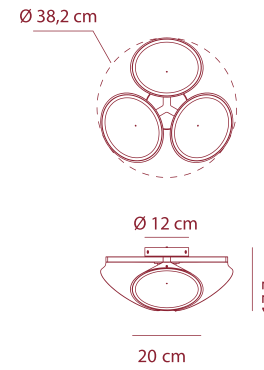

## PL ORCHID

**Source:**  
**LED** 3 x 15W - diffused beam - 3000K  
 CRI 90 - 3 x ~882 lm - 59 lm/W

CE IP20 +LED

### COLOURS

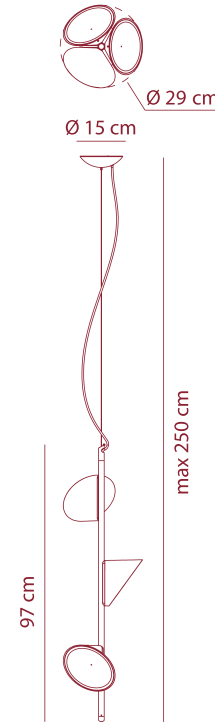

## SP ORCHI 3

**Source:**  
**LED** 3 x 15W - diffused beam - 3000K  
 CRI 90 - 3 x ~882 lm - 59 lm/W

CE IP20 +LED

### COLOURS



### FINISH

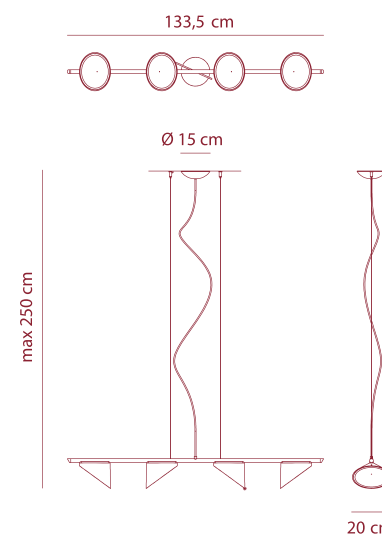

## SP ORCHI 4

**Source:**  
**LED** 4 x 15W - diffused beam - 3000K  
 CRI 90 - 4 x ~882 lm - 59 lm/W

CE IP20 +LED

### COLOURS



### FINISH



## Orchid

design Rainer Mutsch

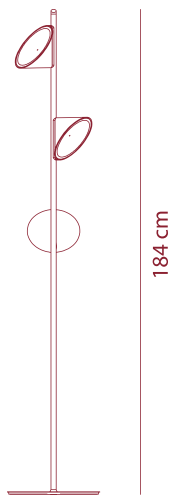

Ø 35 cm

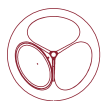

Collection consisting of aluminium wall lamps, ceiling lamps, suspended lamps and floor lamps. Built-in dimmable LED light source.

Collezione composta da lampade da parete, lampade da soffitto, lampade a sospensione e lampade da terra in alluminio. La sorgente luminosa è a LED integrato dimmerabile.

### PT ORCHID

#### Source:

**LED** 3 x 15W - warm light 3000K  
CRI 90 - 3 x ~882 lm - 59 lm/W

CE IP20 - dimmable 220-240VAc **LED**

#### COLOURS

white sand

#### FINISH

white metal

sand metal

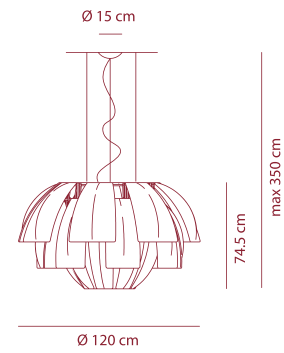

### SP PLU 120

#### Source:

**E27** 6 x Max 16W LED or  
6 x Max 20W fluo or  
6 x 70W halo

CE IP20 **+LED**

#### COLOUR

white

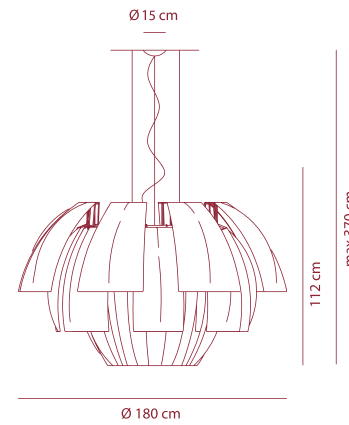

### SP PLU 180

#### Source:

**E27** 6 x Max 16W LED or  
6 x Max 20W fluo or  
6 x 70W halo

CE IP20 **+LED**

#### COLOUR

white

## Plumage

design Vanessa Vivian

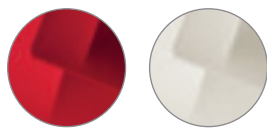

Collection consisting of suspended lamps and floor lamps with white metal frame and fabric diffusers covered with flame-retardant TREVIRA® CS. Screw fitting light source.

Collezione composta da lampade da sospensione e lampade da terra con struttura in metallo verniciato bianco e diffusori in tessuto TREVIRA® CS ignifugato. Sorgente luminosa con attacco a vite.

#### COMPOSITION/COMPOSIZIONE

Fireproof TREVIRA® CS fabric - 100% polyester

Tessuto TREVIRA® CS ignifugo - 100% poliestere

Glow Wire Test (EN 60598-1): 960°C

#### FIREPROOF CLASS/CLASSE IGNIFUGAZIONE

I = C1, F = M1 (NF P 92501-7), D = B1 (DIN 4102), EN 1021/1-2,

GB = Crib 5, IMO A 652, GB = BS 7176 Medium Hazard

#### WEIGHT/PESO

single fabric: 340 ± 5% gr/m²

#### AVAILABLE UPON REQUEST

orange fuchsia light grey  
brown red light green  
multicolor

#### COLOUR

white

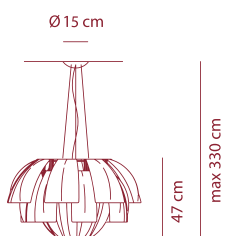

46

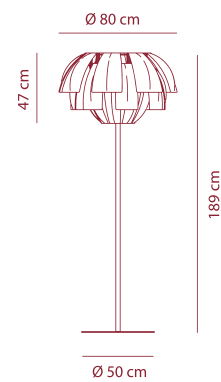

### PT PLU 080

#### Source:

**E27** 3 x Max 16W LED or  
3 x Max 20W fluo dimmable or  
3 x Max 70W halo

CE IP20 - dimmable **+LED**

#### COLOUR

white

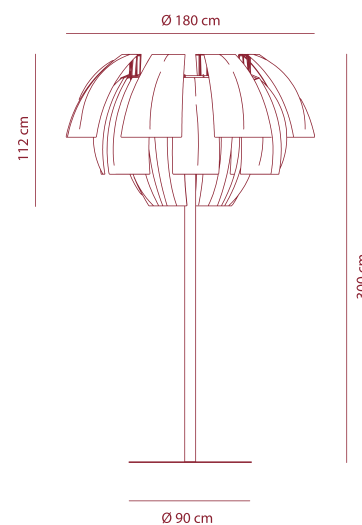

### PT PLU 180

#### Source:

**E27** 3 x Max 16W LED or  
6 x Max 20W fluo or  
6 x 70W halo

CE IP20 - dimmable **+LED**

#### COLOUR

white



## Polia LED

design Manuel Vivian

Collection consisting of metal wall lamps available in several colours and sizes.  
Built-in dimmable LED light source.

Collezione di lampade da parete in metallo, disponibile in vari colori e dimensioni.  
Sorgente luminosa a LED integrato dimmerabile.

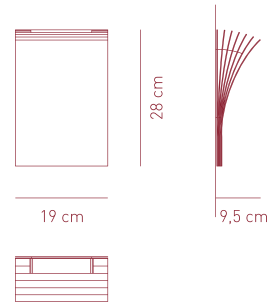

### AP POLIA P

**Source:**  
**LED** 16W - diffused beam - 3000K  
CRI 90 - ~957 lm - 60 lm/W



220-240VAC **LED**

### COLOURS

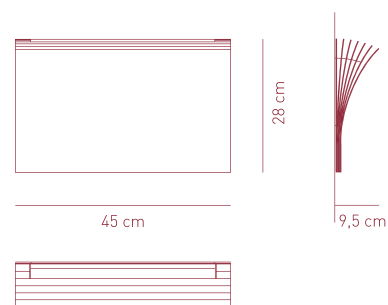

### AP POLIA G

**Source:**  
**LED** 24W - diffused beam - 3000K  
CRI 90 - ~1436 lm - 60 lm/W



220-240VAC **LED**

### COLOURS



## Rythmos

design Serge & Robert Cornelissen

Collection consisting of wall lamps and suspended lamps in white metal.  
Built-in LED light source mono-emitting or bi-emitting.

Collezione composta da lampade da parete e lampade a sospensione in metallo bianco. Sorgente luminosa a LED integrato monoemissione o biemissione.

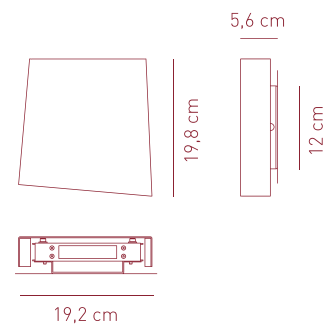

### RYTHMOS WALL

**Source:**  
**LED** 9W (monoemitting)  
- diffused beam - 3000K

**LED** 18W (biemitting)  
- diffused beam - 3000K  
CRI 85 - ~397 lm - 44 lm/W (monoemitting)  
CRI 85 - ~802 lm - 45 lm/W (biemitting)



### COLOUR

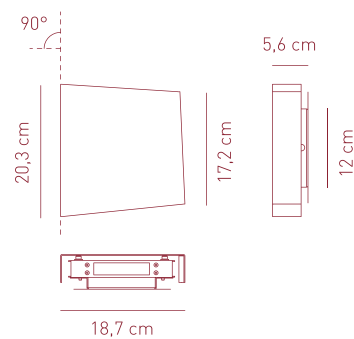

### RYTHMOS HEAD

**Source:**  
**LED** 9W (monoemitting)  
- diffused beam - 3000K

**LED** 18W (biemitting)  
- diffused beam - 3000K  
CRI 85 - ~397 lm - 44 lm/W (monoemitting)  
CRI 85 - ~802 lm - 45 lm/W (biemitting)



### COLOUR

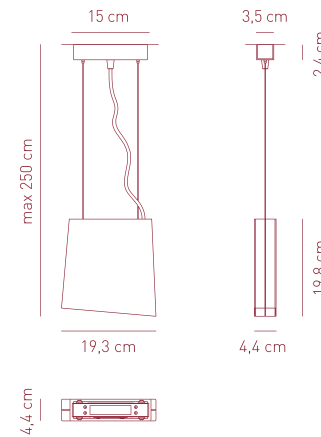

### RYTHMOS SUSPENSION

**Source:**  
**LED** 9W (monoemitting)  
- diffused beam - 3000K

**LED** 15W (biemitting)  
- diffused beam - 3000K  
CRI 85 - ~397 lm - 44 lm/W (monoemitting)  
CRI 85 - ~628 lm - 42 lm/W (biemitting)



### COLOURS



## Shatter LED

design Serge & Robert Cornelissen

Collection consisting of wall lamp, ceiling lamps and suspended lamps in white aluminium. Built-in dimmable LED light source.

Collezione composta da lampada da parete, lampade da soffitto e lampada a sospensione in alluminio bianco. Sorgente luminosa a LED integrato dimmerabile.

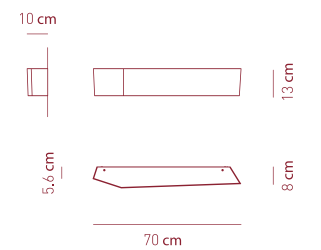

### AP SHATTE LED

**Source:**  
**LED** 32,8W - diffused beam - 3000K  
CRI 80 - ~2976 lm - 90 lm/W



### COLOUR



### FINISH

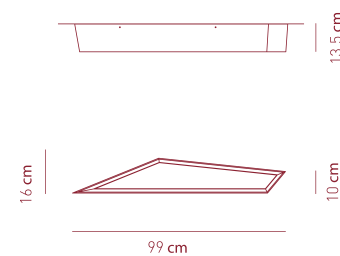

### PL SHATT P LED

**Source:**  
**LED** 32,8W - diffused beam - 3000K  
CRI 80 - ~2080 lm - 63 lm/W



### COLOUR



### FINISH

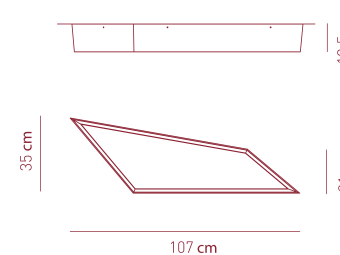

### PL SHATT M LED

**Source:**  
**LED** 65,6W - diffused beam - 3000K  
CRI 80 - ~4960 lm - 76 lm/W



### COLOURS



### FINISH



## Shatter LED

design Serge & Robert Cornelissen

Collection consisting of wall lamp, ceiling lamps and suspended lamps in white aluminium. Built-in dimmable LED light source.

Collezione composta da lampada da parete, lampade da soffitto e lampada a sospensione in alluminio bianco. Sorgente luminosa a LED integrato dimmerabile.

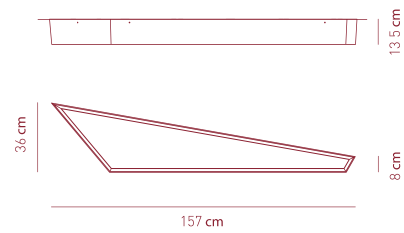

### PL SHATT G LED

**Source:**  
**LED** 98,4W - diffused beam - 3000K  
CRI 80 - ~7440 lm - 76 lm/W



### COLOUR

wrinkled white aluminium

### FINISH

white

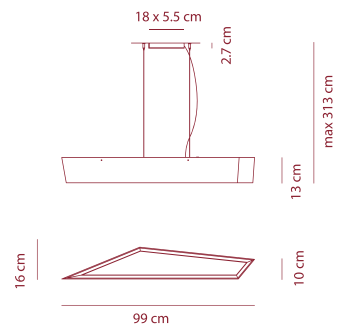

### SP SHATT P LED downward light only

**Source:**  
**LED** 32,8W - diffused beam - 3000K  
CRI 80 - ~2080 lm - 63 lm/W



### COLOUR

wrinkled white aluminium

### FINISH

white canopy

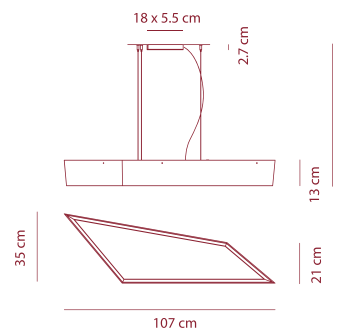

### SP SHATT M LED downward light only

**Source:**  
**LED** 65,6W - diffused beam - 3000K  
CRI 80 - ~4960 lm - 76 lm/W



### COLOUR

wrinkled white aluminium

### FINISH

white canopy

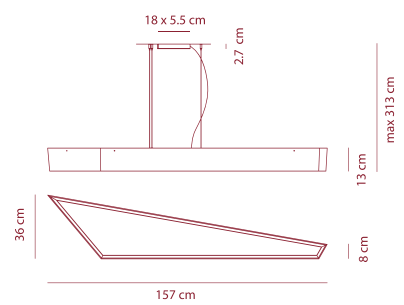

### SP SHATT G LED downward light only

**Source:**  
**LED** 98,4W - diffused beam - 3000K  
CRI 80 - ~7440 lm - 76 lm/W



### COLOUR

wrinkled white aluminium

### FINISH

white canopy

## Skin

design Manuel Vivian

Collection consisting of ceiling lamps and suspended lamps. The lampshade is covered with flame-retardant eco-leather. Screw fitting or built-in dimmable LED light source.

Collezione composta da lampade da soffitto e lampade a sospensione con paralume in ecopelle ignifuga. Sorgente luminosa con attacco a vite o a LED integrato dimmerabile.

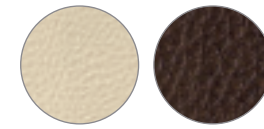

### COMPOSITION/COMPOSIZIONE

Flame retardant Eco-leather - 87% PVC + 13% polyester  
Extra smooth flame retardant pongé fabric - 100% polyester

Eco pelle ignifuga - 87% PVC + 13% poliestere  
Tessuto ignifugato pongé superliscio - 100% poliestere

Glow Wire Test (EN 60598-1): 960°C

### WEIGHT/PESO

550 ± 5% gr/m<sup>2</sup>

### AVAILABLE UPON REQUEST



### RADIAL DIFFUSER UPON REQUEST

warm white

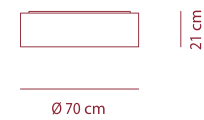

### PL SKI 070

**Source:**  
**E27** 2 x Max 16W LED or  
2 x Max 20W fluo



### COLOUR

white

### RADIAL DIFFUSER

white



### PL SKI 100

**Source:**  
**E27** 3 x Max 16W LED or  
3 x Max 23W fluo



### COLOUR

white

### RADIAL DIFFUSER

white



### PL SKI 160

**Source:**  
**E27** 5 x Max 16W LED or  
5 x Max 23W fluo



### COLOUR

white

### RADIAL DIFFUSER

white



## Skin

design Manuel Vivian

Collection consisting of ceiling lamps and suspended lamps. The lampshade is covered with flame-retardant eco-leather. Screw fitting or built-in dimmable LED light source.

Collezione composta da lampade da soffitto e lampade a sospensione con paralume in ecopelle ignifuga. Sorgente luminosa con attacco a vite o a LED integrato dimmerabile.

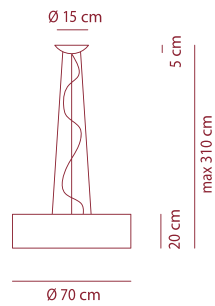

### SP SKI 070 with upward & downward lighting

**Source:**  
**E27** 4 x Max 16W LED or  
4 x Max 20W fluo

CE IP20 +LED

#### COLOUR

○ white

#### RADIAL DIFFUSER

○ white

#### FINISH

○ white canopy

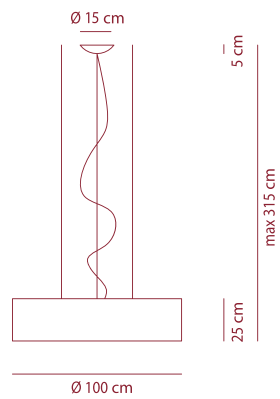

### SP SKI 100 with upward & downward lighting

**Source:**  
**E27** 6 x Max 16W LED or  
6 x Max 20W fluo

CE IP20 +LED

### SP SKI 100 LED

**Source:**  
**LED** 95W - diffused beam - 3000K  
CRI 90 - ~5896 lm - 62 lm/W

CE IP20 - dimmable DALI +LED

#### COLOUR

○ white

#### RADIAL DIFFUSER

○ white

#### FINISH

○ white canopy

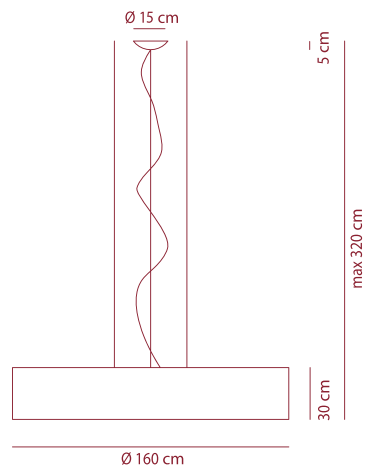

### SP SKI 160 with upward & downward lighting

**Source:**  
**E27** 6 x Max 16W LED or  
6 x Max 20W fluo

CE IP20 +LED

### SP SKI 100 LED

**Source:**  
**LED** 95W - diffused beam - 3000K  
CRI 90 - ~5896 lm - 62 lm/W

CE IP20 - dimmable DALI +LED

#### COLOUR

○ white

#### RADIAL DIFFUSER

○ white

#### FINISH

○ white canopy

## Skirt

design Manuel Vivian

Collection consisting of ceiling, suspended and table lamps in flame-retardant TREVIRA®CS fabric. The fabric can also come in a double-layer version with an exterior black net fabric. A decorative inner lampshade (also printable with customized graphic) available only for some of the suspended and ceiling lamps.

Collezione di lampade da soffitto, a sospensione e da tavolo con paralume in tessuto ignifugato TREVIRA® CS. Disponibile anche con tessuto esterno retato nero. Un paralume decorativo interno (stampabile anche con grafica personalizzata) è disponibile per alcune lampade a sospensione e lampade da soffitto.

#### LAMPSHADES COLOURS/COLORI PARALUMI

The fabrics are available individually or combined with black net. For the version with overlapping black net add "NE" before the color code.

I tessuti sono disponibili singolarmente o accoppiati a rete nera. Per la versione con rete nera aggiungere "NE" anteposto al codice colore.

#### COMPOSITION/COMPOSIZIONE

Fireproof TREVIRA® CS fabric - 100% polyester  
Tessuto TREVIRA® CS ignifugo - 100% poliestere

Glow Wire Test (EN 60598-1): 960 °C

#### FIREPROOF CLASS/CLASSE IGNIFUGAZIONE

I = C1, F = M1 (NF P 92501-7), D = B1 (DIN 4102), EN 1021/1-2,  
GB = Crib 5, IMO A 652, GB = BS 7176 Medium Hazard

#### WEIGHT/PESO

black net finish fabric/Finitura a rete nera: 214 ± 5% gr/m2  
single fabric/tessuto singolo: 340 ± 5% gr/m2

#### AVAILABLE UPON REQUEST

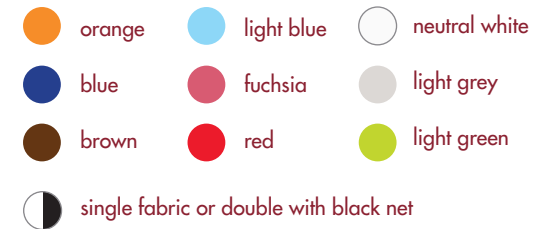

### AP SKR 028

#### COLOUR

○ white

**Source:**  
**FLUO 2610** 1 x 36W

CE IP20

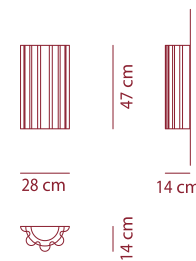

### PL SKR 070

#### COLOUR

○ white

**Source:**  
**E27** 1 x Max 16W LED or  
1 x Max 23W fluo or  
1 x Max 70W halo

CE IP20 +LED

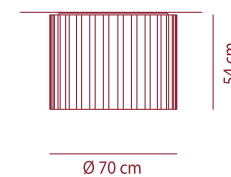

### PL SKR 100

#### COLOUR

○ white

**Source:**  
**E27** 3 x Max 16W LED or  
3 x Max 23W fluo or  
3 x Max 70W halo

CE IP20 +LED

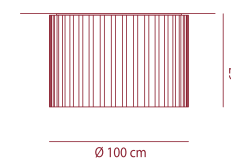

### PL SKR 150

#### COLOUR

○ white

**Source:**  
**E27** 4 x Max 16W LED or  
4 x Max 23W fluo or  
4 x Max 70W halo

CE IP20 +LED

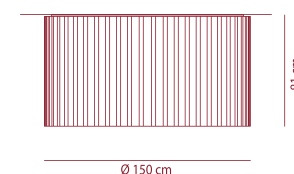

# Skirt

design Manuel Vivian

Collection consisting of ceiling, suspended and table lamps in flame-retardant TREVIRA®CS fabric. The fabric can also come in a double-layer version with an exterior black net fabric. A decorative inner lampshade (also printable with customized graphic) available only for some of the suspended and ceiling lamps.

Collezione di lampade da soffitto, a sospensione e da tavolo con paralume in tessuto ignifugato TREVIRA® CS. Disponibile anche con tessuto esterno retato nero. Un paralume decorativo interno (stampabile anche con grafica personalizzata) è disponibile per alcune lampade a sospensione e lampade da soffitto.

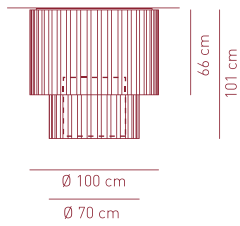

## PL SK 100 2

COLOUR



Source:  
**E27** 3 x Max 16W LED or  
 3 x Max 23W fluo or  
 3 x Max 70W halo

CE IP20 +LED

### DECORATIVE LAMPSHADE OPTIONAL

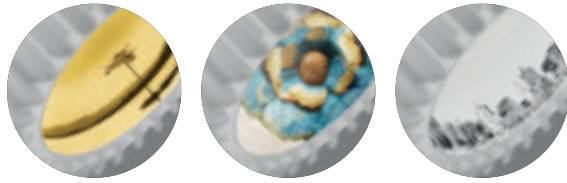

Optional inner decorative lampshade.  
 Available only for PL/SP SK 100 2 & PL/SP SK 150 2

Inner decorative printed lampshade with customized graphic:  
 contact Axo Light customer service for further info

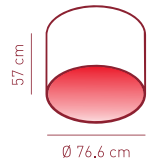
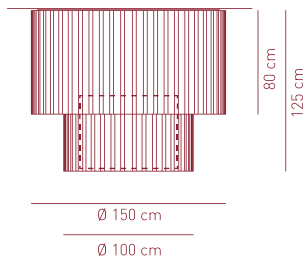

## PL SK 150 2

COLOUR



Source:  
**E27** 4 x Max 16W LED or  
 4 x Max 23W fluo or  
 4 x Max 70W halo

CE IP20 +LED

### DECORATIVE LAMPSHADE OPTIONAL

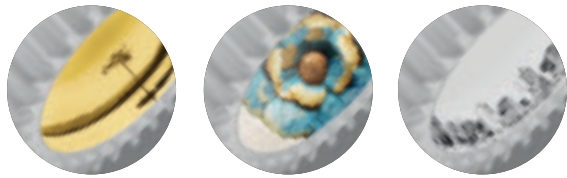

Optional inner decorative lampshade.  
 Available only for PL/SP SK 100 2 & PL/SP SK 150 2

Inner decorative printed lampshade with customized graphic:  
 contact Axo Light customer service for further info

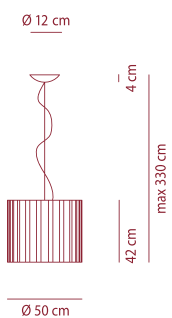

## SP SKR 050

COLOUR



Source:  
**E27** 1 x Max 20W LED or  
 1 x Max 33W fluo or  
 1 x Max 70W halo

CE IP20 +LED

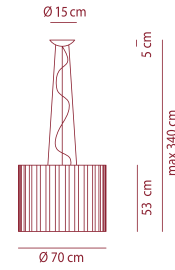

## SP SKR 070

COLOUR



Source:  
**E27** 1 x Max 20W LED or  
 1 x Max 33W fluo or  
 1 x Max 70W halo

CE IP20 +LED

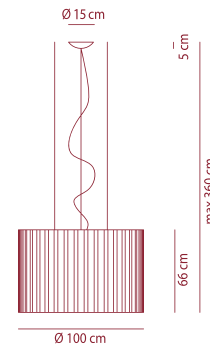

## SP SKR 100 with upward & downward lighting

COLOUR



Source:  
**E27** 4 x Max 20W LED or  
 4 x Max 33W fluo or  
 4 x Max 70W halo

CE IP20 +LED

## SP SKR 100 LED

Source:  
**LED** 95W - diffused beam - 3000K  
 CRI 90 - ~6209 lm - 65 lm/W

CE IP20 dimmable DALI LED

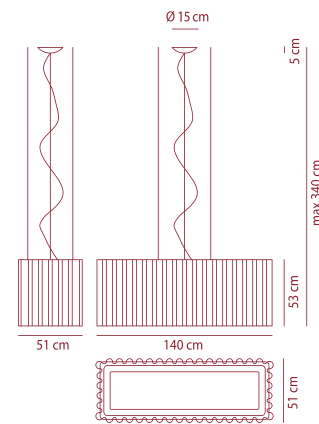

## SP SKR 140

COLOUR



Source:  
**E27** 4 x Max 16W LED or  
 4 x Max 23W fluo or  
 4 x Max 57W halo

CE IP20 +LED

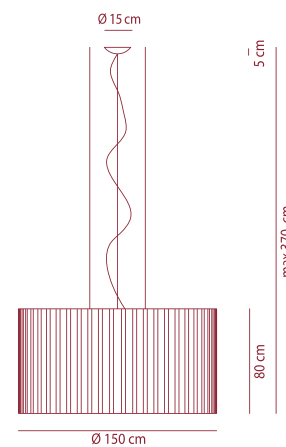

## SP SKR 150 with upward & downward lighting

COLOUR



Source:  
**E27** 4 x Max 16W + 1 x Max 12W LED or  
 5 x Max 23W fluo or  
 4 x Max 70W + 1 x 57W halo

CE IP20 +LED

## SP SKR 150 LED

Source:  
**LED** 95W diffused beam - 3000K  
 CRI 90 - ~6209 lm - 65 lm/W

CE IP20 dimmable DALI LED



## Skirt

design Manuel Vivian

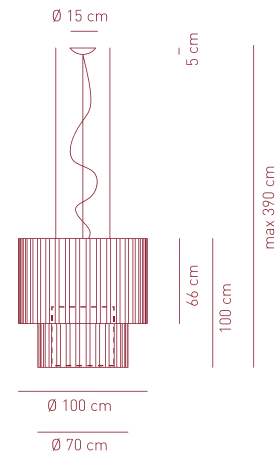

Collection consisting of ceiling, suspended and table lamps in flame-retardant TREVIRA®CS fabric. A decorative inner lampshade (also printable with customized graphic) available only for some of the suspended and ceiling lamps.  
Collezione di lampade da soffitto, a sospensione e da tavolo con paralume in tessuto ignifugato TREVIRA® CS. Un paralume decorativo interno (stampabile anche con grafica personalizzata) è disponibile per alcune lampade a sospensione e lampade da soffitto.

### SP SK 100 2 with upward & downward lighting

COLOUR



Source:  
**E27** 4 x Max 20W LED or  
4 x Max 33W fluo or  
4 x Max 70W halo

CE IP20 +LED

### SP SK 100 2 LED

Source:  
**LED** 95W - diffused beam - 3000K  
CRI 90 - ~5896 lm - 62 lm/W

CE IP20 dimmable DALI LED

### DECORATIVE LAMP SHADE OPTIONAL

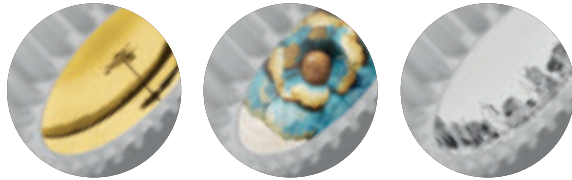

Optional inner decorative lampshade.  
Available only for PL/SP SK 100 2 & PL/SP SK 150 2

Inner decorative printed lampshade with customized graphic:  
contact Axo Light customer service for further info

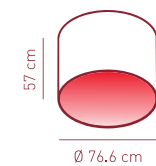
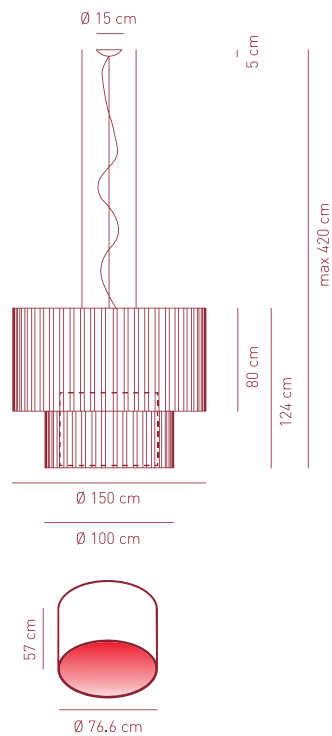

### SP SK 150 2 with upward & downward lighting

COLOUR



Source:  
**E27** 4 x Max 16W + 1 x Max 12W LED or  
5 x Max 23W fluo or  
4 x Max 70W + 1 x Max 57W halo

CE IP20 +LED

### SP SK 150 2 LED

Source:  
**LED** 95W - diffused beam - 3000K  
CRI 90 - ~5896 lm - 62 lm/W

CE IP20 dimmable DALI LED

### DECORATIVE LAMP SHADE OPTIONAL



Optional inner decorative lampshade.  
Available only for PL/SP SK 100 2 & PL/SP SK 150 2

Inner decorative printed lampshade with customized graphic:  
contact Axo Light customer service for further info

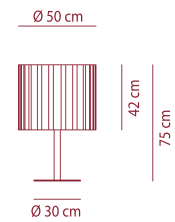

### LT SKR 050

COLOUR



Source:  
**E27** 3 x Max 16W LED or  
3 x Max 23W fluo or  
3 x Max 46W halo

CE IP20 +LED

## Sol

design Manuel Vivian

Ceiling lamp in white aluminium. Built-in LED light source.  
Lampada da soffitto in alluminio bianco. Sorgente luminosa a LED.

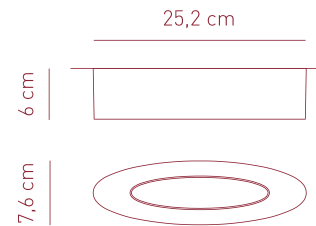

### SOL CEILING

COLOUR



Source:  
**LED** 9W - diffused beam - 3000K  
CRI 85 - 524 lm - 52 lm/W

CE IP20 LED

## Spillray

design Manuel Vivian

Collection consisting of wall lamps, recessed ceiling lamps and suspended lamps.  
The diffusers are made of glass with chrome-plated metal frame.  
Available in several colours and sizes. Halo or LED light source.

Collezione di lampade da parete, lampade da soffitto ad incasso e lampade a sospensione in vetro con montatura in metallo cromato. Disponibile in vari colori e dimensioni. Sorgente luminosa alogena o a LED.

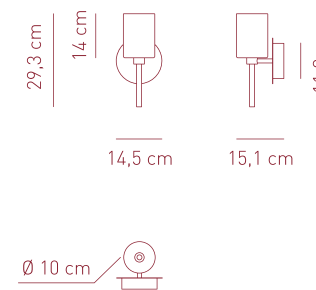

### AP SPILLR

COLOURS



Source:  
**G4** 1 x Max 20W 12VAc halo **included**

CE IP20 dimmable phase cut



FINISH

**G4** 1 x 1,5W 12Vdc **LED included**  
- 12Vdc **only LED bulb**

CE IP20 LED



# Spillray

design Manuel Vivian

Collection consisting of wall lamps, recessed ceiling lamps and suspended lamps. The diffusers are made of glass with chrome-plated metal frame. Available in several colours and sizes. Halo or LED light source.  
 Collezione di lampade da parete, lampade da soffitto ad incasso e lampade a sospensione in vetro con montatura in metallo cromato. Disponibile in vari colori e dimensioni. Sorgente luminosa alogena o a LED.

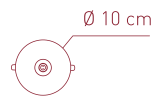
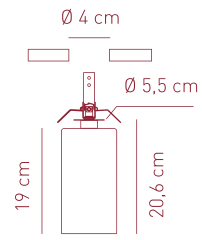

## PL SPIL M I

**Source:**  
**G4** 1 x Max 20W 12V<sub>ac</sub> halo **included**  
 CE IP20 with dedicated PSU  
 transformer not included

- COLOURS**
- crystal
  - red
  - grey

- FINISH**
- chrome

## PL SPIL M I LED

**Source:**  
**G4** 1 x 1,5W 12V<sub>dc</sub> **LED included**  
 -only LED bulb  
 CE IP20 LED

driver not included

hole Ø 5 cm  
 min depth 10 cm

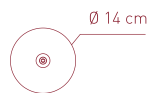
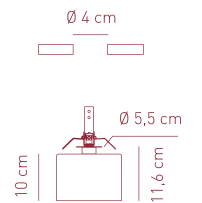

## PL SPIL G I

**Source:**  
**G4** 1 x Max 20W 12V<sub>ac</sub> halo **included**  
 CE IP20 with dedicated PSU  
 transformer not included

- COLOURS**
- crystal
  - red
  - grey

- FINISH**
- chrome

## PL SPIL G I LED

**Source:**  
**G4** 1 x 1,5W 12 V<sub>dc</sub> **LED included**  
 -only LED bulb  
 CE IP20 LED

driver not included

hole Ø 5 cm  
 min depth 10 cm

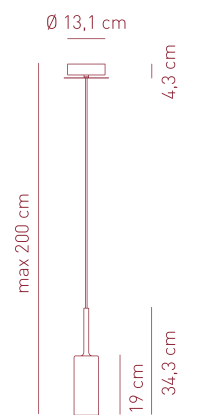

## SP SPILL P

**Source:**  
**G4** 1 x Max 20W 12V<sub>ac</sub> halo **included**  
 CE IP20 dimmable phase cut  
 transformer not included  
**G4** 1 x 1,5W 12V<sub>dc</sub> **LED included**  
 -only LED bulb  
 CE IP20 LED

- COLOURS**
- crystal
  - red
  - grey
  - metallic bronze

- FINISH**
- chrome

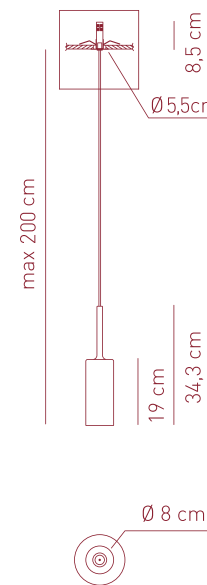

## SP SPIL P I (recessed)

**Source:**  
**G4** 1 x Max 20W 12V<sub>ac</sub> halo **included**  
 CE IP20 with dedicated PSU  
 transformer not included  
**G4** LED 1 x 1,5W 12V<sub>dc</sub> **LED included**  
 - only LED bulb  
 CE IP20 LED

- COLOURS**
- crystal
  - red
  - grey
  - metallic bronze

- FINISH**
- chrome

driver not included

hole Ø 4 cm  
 min depth 10 cm

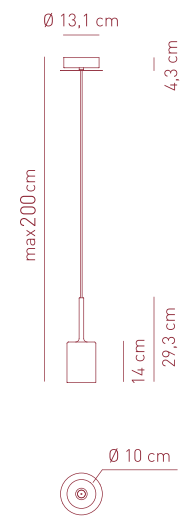

## SP SPILL M

**Source:**  
**G4** 1 x Max 20W 12V<sub>ac</sub> halo **included**  
 CE IP20 dimmable phase cut  
 transformer not included  
**G4** 1 x 1,5W 12V<sub>dc</sub> **LED included**  
 - only LED bulb  
 CE IP20 LED

- COLOURS**
- crystal
  - red
  - grey
  - metallic bronze

- FINISH**
- chrome

driver not included

hole Ø 5 cm  
 min depth 10 cm

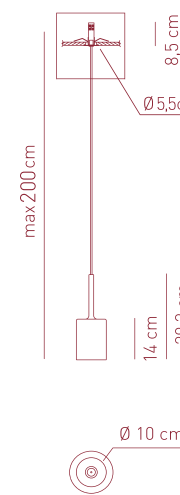

## SP SPIL M I (recessed)

**Source:**  
**G4** 1 x Max 20W 12V<sub>ac</sub> halo **included**  
 CE IP20 with dedicated PSU  
 transformer not included  
**G4** 1 x 1,5W 12V<sub>dc</sub> **LED included**  
 - only LED bulb  
 CE IP20 LED

- COLOURS**
- crystal
  - red
  - grey
  - metallic bronze

- FINISH**
- chrome

driver not included

hole Ø 4 cm  
 min depth 10 cm



# Spillray

design Manuel Vivian

Collection consisting of wall lamps, recessed ceiling lamps and suspended lamps. The diffusers are made of glass with chrome-plated metal frame. Available in several colours and sizes. Halo or LED light source.  
*Collezione di lampade da parete, lampade da soffitto ad incasso e lampade a sospensione in vetro con montatura in metallo cromato. Disponibile in vari colori e dimensioni. Sorgente luminosa alogena o a LED.*

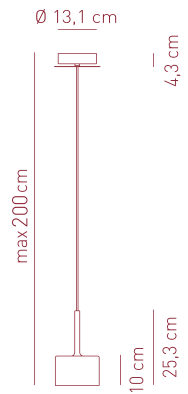

## SP SPILL 6

**Source:**  
**G4** 1 x Max 20W 12V<sub>ac</sub> halo **included**



**G4** 1 x 1,5W 12V<sub>dc</sub> **LED included**  
**-only LED bulb**



## COLOURS

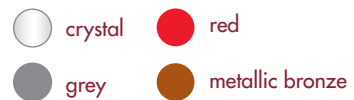

## FINISH

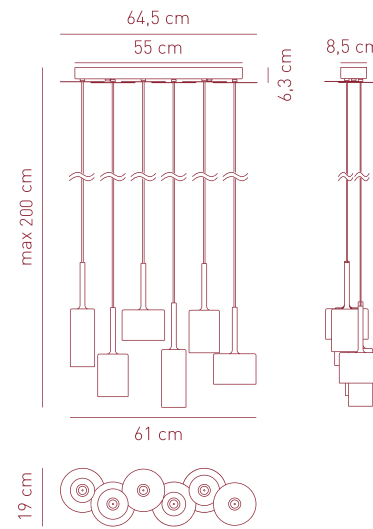

## SP SPILL 6

**Source:**  
**G4** 6 x Max 20W 12V<sub>ac</sub> halo **included**



**G4** 6 x 1,5W 12V<sub>dc</sub> **LED included**  
**-only LED bulb**



## COLOURS



## FINISH

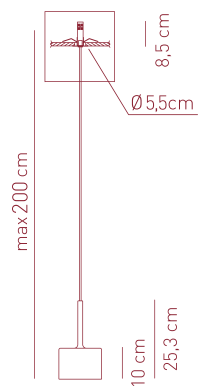
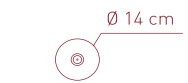

## SP SPILL G I (recessed)

**Source:**  
**G4** 1 x Max 20W 12V<sub>ac</sub> halo **included**



transformer not included

**G4** 1 x 1,5W 12V<sub>dc</sub> **LED included**  
**-only LED bulb**



## COLOURS

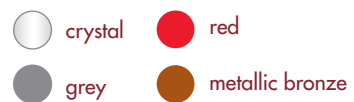

## FINISH

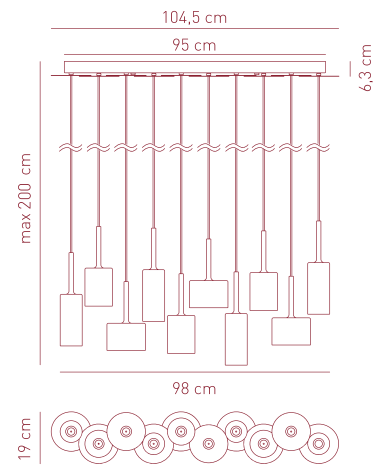

## SP SPILL 10

**Source:**  
**G4** 10 x Max 20W 12V<sub>ac</sub> halo **included**



**G4** 10 x 1,5W 12V<sub>dc</sub> **LED included**  
**-only LED bulb**



## COLOURS



## FINISH

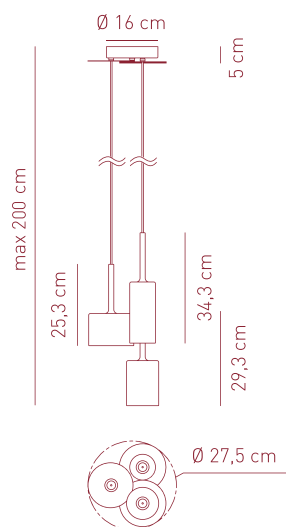
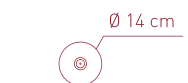

## SP SPILL 3

**Source:**  
**G4** 3 x Max 20W 12V<sub>ac</sub> halo **included**



**G4** 3 x 1,5W 12V<sub>dc</sub> **LED included**  
**-only LED bulb**



## COLOURS

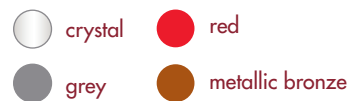

## FINISH

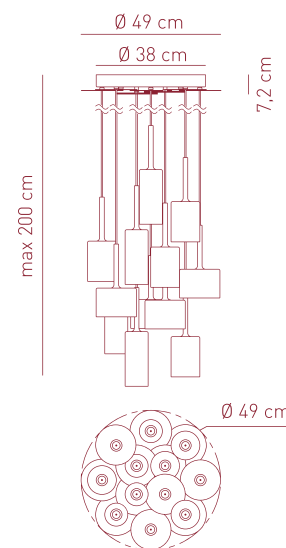

## SP SPILL 12

**Source:**  
**G4** 12 x Max 20W 12V<sub>ac</sub> halo **included**



**G4** 12 x 1,5W 12V<sub>dc</sub> **LED included**  
**-only LED bulb**



## COLOURS



## FINISH

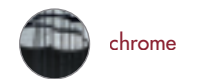

## Spillray

design Manuel Vivian

Collection consisting of wall lamps, recessed ceiling lamps and suspended lamps. The diffusers are made of glass with chrome-plated metal frame. Available in several colours and sizes. Halo or LED light source.  
 Collezione di lampade da parete, lampade da soffitto ad incasso e lampade a sospensione in vetro con montatura in metallo cromato. Disponibile in vari colori e dimensioni. Sorgente luminosa alogena o a LED.

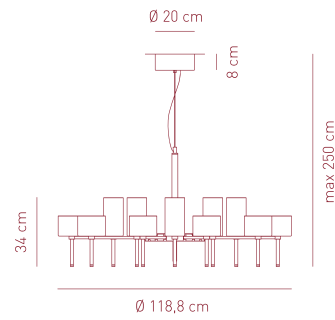

### SP SPIL 20

**Source:**  
**G4** 20 x Max 20W 12 Vac halo **included**  
 CE IP20 dimmable phase cut

### COLOURS

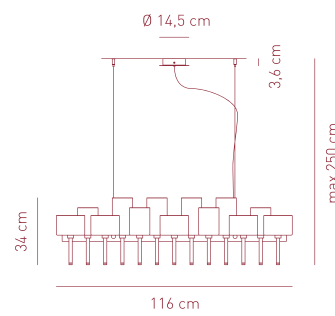
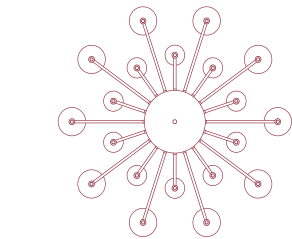

### SP SPIL 26

**Source:**  
**G4** 26 x Max 20W 12 Vac halo **included**  
 CE IP20 dimmable phase cut

### COLOURS

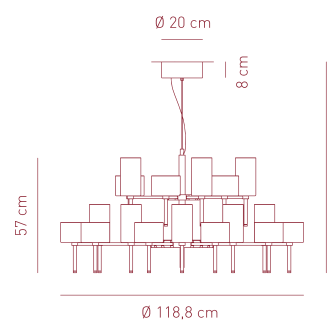
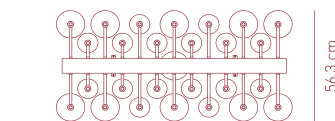

### SP SPIL 30

**Source:**  
**G4** 30 x Max 20W 12 Vac halo **included**  
 CE IP20 dimmable phase cut

### COLOURS

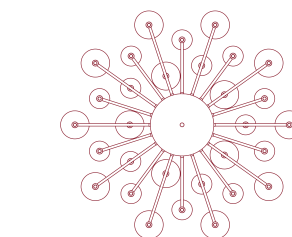

## Spiry

design Giovanni Barbato

Suspended lamp in white bent aluminium. Screw fitting light source.  
 Lampada a sospensione in alluminio curvato bianco. Sorgente luminosa con attacco a vite.

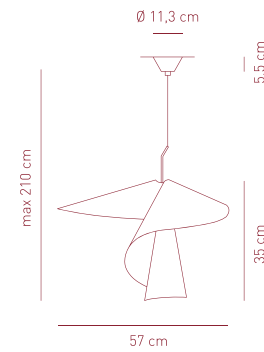

### SP SPIRY

**Source:**  
**E27** 1 x Max 20W LED or  
 1 x Max 23W fluo or  
 1 x Max 100W halo

CE IP20

### COLOUR



### FINISH



## Stilla

design Manuel Vivian

Collection of aluminium suspended lamps, also in a recessed version. Available in several colours. Built-in LED light source.

Lampade a sospensione in alluminio in vari colori. Disponibile anche nella versione ad incasso. Sorgente luminosa a LED integrato.

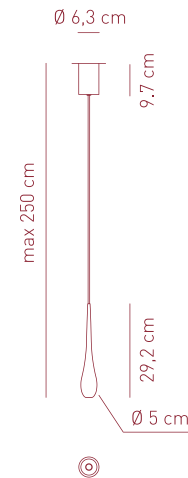

### STILLA SUSPENSION monocanopy

**Source:**  
**LED** 6,5W - 47° or 60° beam 3000K  
 CRI 80 - 47° beam: ~688 lm - 106 lm/W  
 CRI 80 - 60° beam: ~688 lm - 103 lm/W

CE IP20

### COLOURS

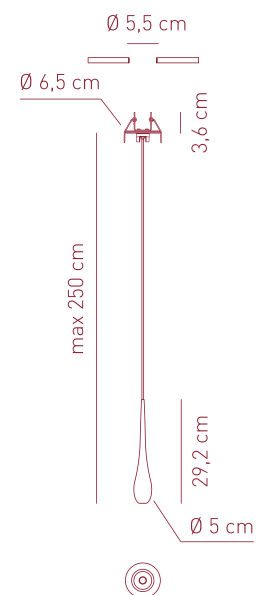

### STILLA SUSPENSION recessed version

**Source:**  
**LED** 6,6W - 350mA - 47° or 60° beam 3000K  
 CRI 80 - 47° beam: ~688 lm - 106 lm/W  
 CRI 80 - 60° beam: ~688 lm - 103 lm/W

CE IP20 with dedicated PSU

### COLOURS



driver not included

for drivers and dimming technology, please refer to our Axo Light pricelist or contact our representatives

hole Ø 5.5  
 min depth 10 cm



## Stormy

design Manuel Vivian

Collection of ceiling or wall lamps with metal frame and removable, washable elastic fabric covering. Screw fitting light source.

Collezione di lampade da soffitto o da parete con struttura metallica e rivestimento in tessuto elasticizzato, sfoderabile e lavabile. Sorgente luminosa con attacco a vite.

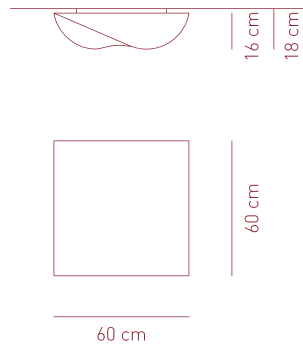

**PL STOR 60**  
application: both as ceiling or wall lamp

**E27** 2 x Max 16W LED or  
2 x Max 70W halo

CE IP20 +LED

### COLOURS

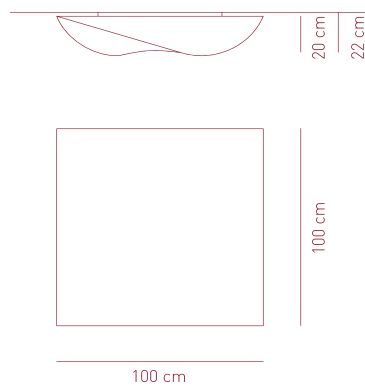

**PL STO 100**  
application: both as ceiling or wall lamp

**Source:**  
**E27** 3 x Max 16W LED or  
3 x Max 70W halo

CE IP20 +LED

### COLOURS



## U-light

design Timo Ripatti

Collection consisting of wall lamps, ceiling lamps and suspended lamps in aluminium. Built-in LED dimmable light source.

Collezione composta da lampade da parete, lampade da soffitto e lampade a sospensione in alluminio. Sorgente luminosa a LED integrato dimmerabile.

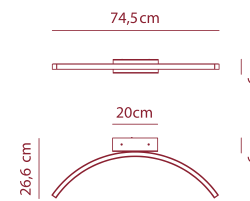

**AP ULI 090**  
application: downlight or  
uplight mounting

**Source:**

**LED** 17W - diffused beam - 3000K  
CRI 90 - ~1332 lm - 78 lm/W

CE IP20 dimmable 1-10V LED

### COLOURS

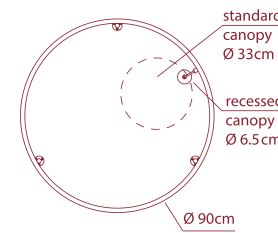
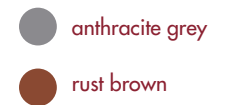

**PL UL X 090**  
application: both as ceiling  
(downlight or uplight mounting) or wall  
lamp (only wallward light)

**Source:**

**LED** 57,6W - diffused beam - 3000K  
CRI 90 - ~4413 lm - 77 lm/W

CE IP20 LED



### COLOURS



for drivers and dimming technology,  
please refer to our Axo Light pricelist  
or contact our representatives

recessed canopy

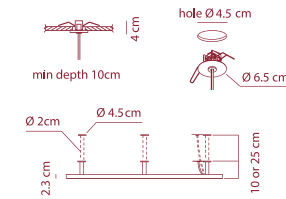

standard canopy

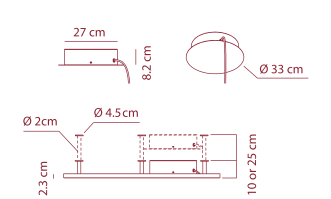

available heights

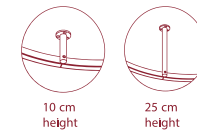

# U-light

design Timo Ripatti

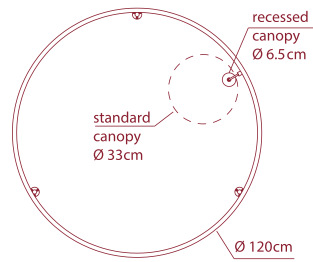

Collection consisting of wall lamps, ceiling lamps and suspended lamps in aluminium. Built-in LED dimmable light source.  
*Collezione composta da lampade da parete, lampade da soffitto e lampade a sospensione in alluminio. Sorgente luminosa a LED integrato dimmerabile.*

**PL UL X 120**  
**application: both as ceiling (downlight or uplight mounting) or wall lamp (only wallward light)**

**COLOURS**

- anthracite grey
- rust brown

**Source:**  
**LED** 86,4W - diffused beam - 3000K  
 CRI 90 - ~6618 lm - 77 lm/W



for drivers and dimming technology, please refer to our Axo Light pricelist or contact our representatives

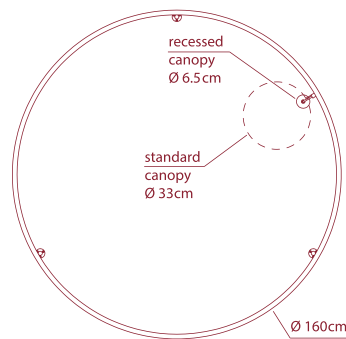
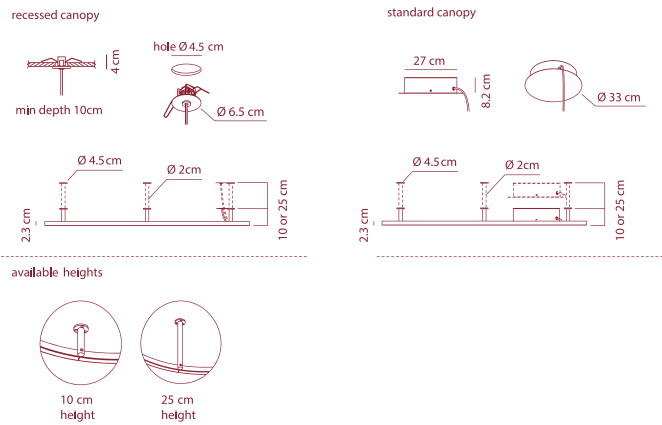

**PL UL X 160**  
**application: both as ceiling (downlight or uplight mounting) or wall lamp (only wallward light)**

**COLOURS**

- anthracite grey
- rust brown

**Source:**  
**LED** 108W - diffused beam - 3000K  
 CRI 90 - ~8274 lm - 77 lm/W



for drivers and dimming technology, please refer to our Axo Light pricelist or contact our representatives

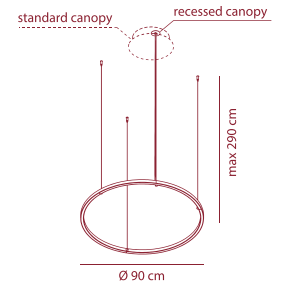
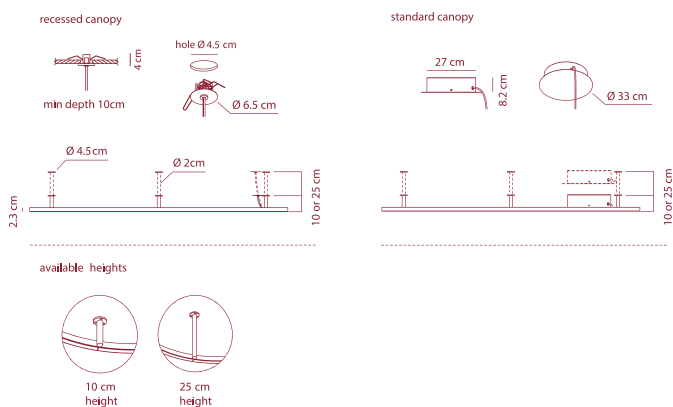

**SP ULA 090**  
**available with recessed or standard canopy**

**Source:**  
**LED** 57,6W - diffused beam - 3000K  
 CRI 90 - ~4413 lm - 77 lm/W



for drivers and dimming technology, please refer to our Axo Light pricelist or contact our representatives

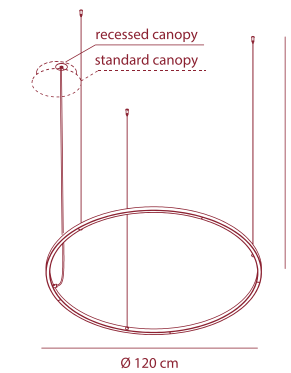
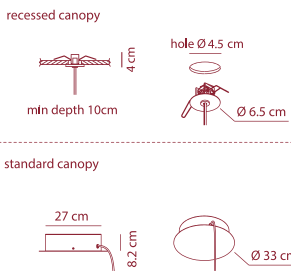

**SP ULA 120**  
**available with recessed or standard canopy**

**Source:**  
**LED** 86,4W - diffused beam - 3000K  
 CRI 90 - ~6618 lm - 77 lm/W



for drivers and dimming technology, please refer to our Axo Light pricelist or contact our representatives

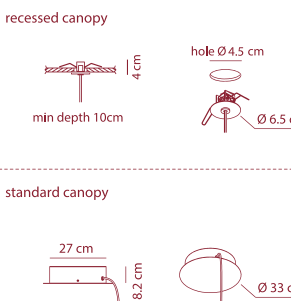



## U-light

design Timo Ripatti

Collection consisting of wall lamps, ceiling lamps and suspended lamps in aluminium. Built-in LED dimmable light source.  
*Collezione composta da lampade da parete, lampade da soffitto e lampade a sospensione in alluminio. Sorgente luminosa a LED integrato dimmerabile.*

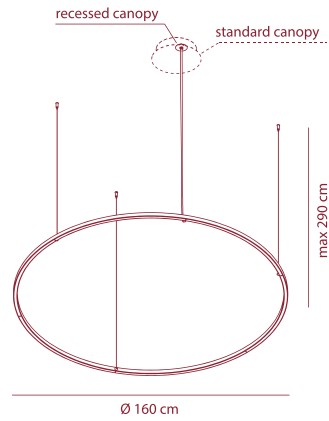

### SP ULA 160

available with recessed or standard canopy

**Source:**  
**LED** 107,8W - diffused beam - 3000K  
 CRI 90 - ~8274 lm - 77 lm/W

CE IP20 LED



for drivers and dimming technology, please refer to our Axo Light pricelist or contact our representatives

### COLOURS

- anthracite grey
- rust brown

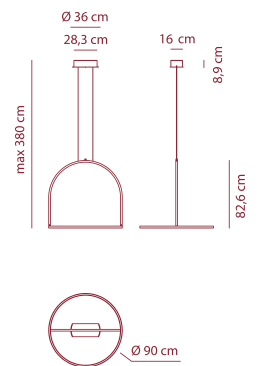
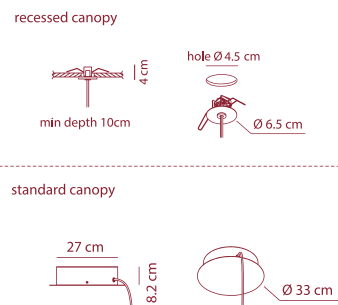

### SP ULI 090

**Source:**  
**LED** 57,6W - diffused beam - 3000K  
 CRI 90 - ~4413 lm - 77 lm/W

CE IP20 LED

### COLOURS

- anthracite grey
- rust brown

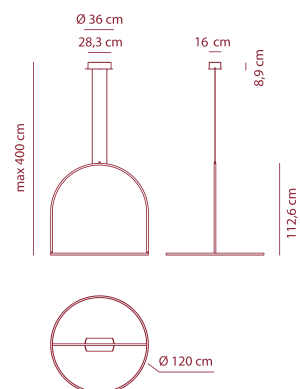

### SP ULI 120

**Source:**  
**LED** 86,4W - diffused beam - 3000K  
 CRI 90 - ~6618 lm - 77 lm/W

CE IP20 LED

### COLOURS

- anthracite grey
- rust brown

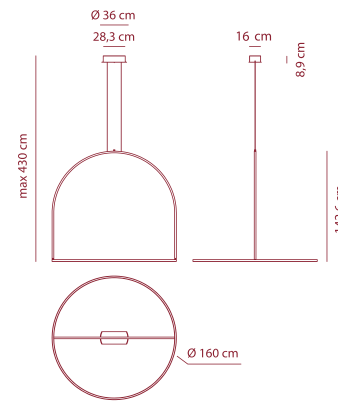

### SP ULI 160

**Source:**  
**LED** 108W - diffused beam - 3000K  
 CRI 90 - ~8274 lm - 77 lm/W

CE IP20 LED

### COLOURS

- anthracite grey
- rust brown

## Ukiyo

design Manuel Vivian

Collection of ceiling or wall lamps with metal frame and white removable, washable elastic mesh fabric covering. Screw fitting light source.  
*Collezione di lampade da parete o da soffitto con struttura metallica e rivestimento in tessuto bianco retato elasticizzato, sfoderabile e lavabile. Sorgente luminosa con attacco a vite.*

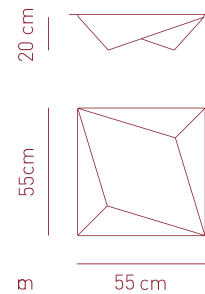

### PL UKIYO P

Application: both as ceiling or wall lamp

### COLOUR

- white

**Source:**  
**E27** 3 x Max 6,5W LED or  
 3 x Max 42W halo

CE IP20 +LED

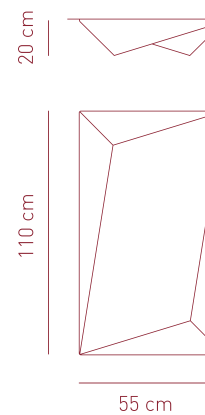

### PL UKI 110

Application: both as ceiling or wall lamp

### COLOUR

- white

**Source:**  
**E27** 3 x Max 16W LED or  
 3 x Max 70W halo

CE IP20 +LED

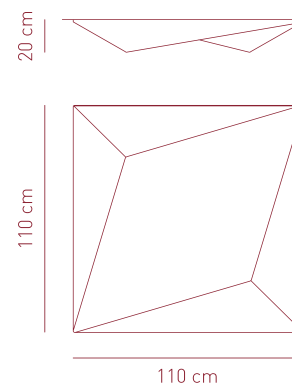

### PL UKIYO G

Application: both as ceiling or wall lamp

### COLOUR

- white

**Source:**  
**E27** 3 x Max 16W LED or  
 3 x Max 70W halo

CE IP20 +LED

# Urban

design Dima Loginoff

Collection consisting of aluminium ceiling lamps and suspended lamps, also in a recessed version. Available in several colours and sizes. Built-in dimmable LED light source.

Collezione composta da lampade da soffitto e lampade a sospensione in alluminio. Disponibile in vari colori e dimensioni. Le sospensioni sono disponibili anche nella versione ad incasso. Sorgente luminosa a LED integrato dimmerabile.

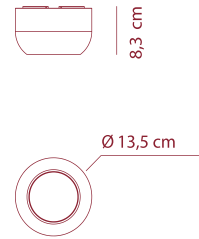

## PL URBAN P

### COLOURS

Source:

**LED** 15W - diffused beam - 3000K  
CRI 90 - ~946 lm - 63 lm/W



- wrinkled white
- matt bronze
- matt nickel

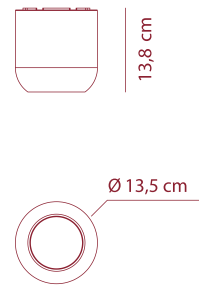

## PL URBAN M

### COLOURS

Source:

**LED** 15W - diffused beam - 3000K  
CRI 90 - ~946 lm - 63 lm/W



- wrinkled white
- matt bronze
- matt nickel

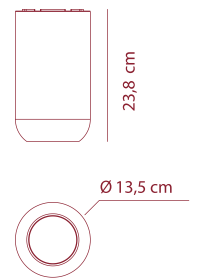

## PL URBAN G

### COLOURS

Source:

**LED** 15W - diffused beam - 3000K  
CRI 90 - ~946 lm - 63 lm/W



- wrinkled white
- matt bronze
- matt nickel

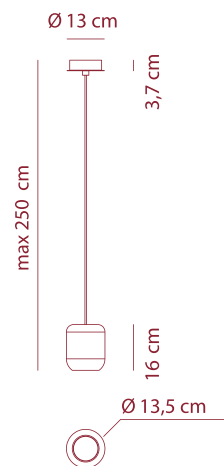

## SP URBAN P downward lighting only

### COLOURS

Source:

**LED** 15W - diffused beam - 3000K  
CRI 90 - ~946 lm - 63 lm/W



- wrinkled white
- matt bronze
- matt nickel

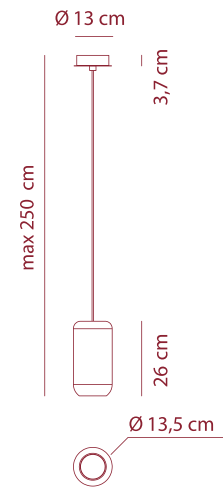

## SP URBAN M downward lighting only

### COLOURS

Source:

**LED** 15W - diffused beam - 3000K  
CRI 90 - ~946 lm - 63 lm/W



- wrinkled white
- matt bronze
- matt nickel

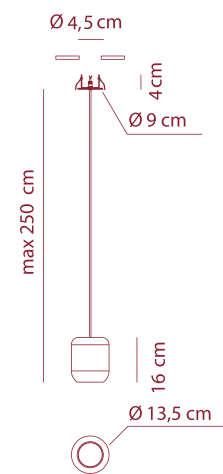

## SP URBA P I recessed downward lighting only

### COLOURS

Source:

**LED** 15W - diffused beam - 3000K  
CRI 90 - ~946 lm - 63 lm/W



- wrinkled white
- matt bronze
- matt nickel

hole  $\varnothing$  4.5 cm  
min depth 10 cm

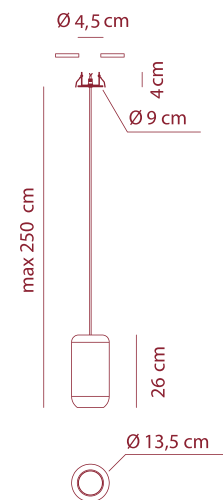

## SP URBA M I recessed downward lighting only

### COLOURS

Source:

**LED** 15W - diffused beam - 3000K  
CRI 90 - ~946 lm - 63 lm/W



- wrinkled white
- matt bronze
- matt nickel

hole  $\varnothing$  4.5 cm  
min depth 10 cm



## Urban mini

design Dima Loginoff

Collection consisting of aluminium ceiling lamps and suspended lamps.  
Available in several colours and sizes Built-in dimmable LED light source.  
Collezione composta da lampade a sospensione e lampade da soffitto in alluminio.  
Disponibile in vari colori e dimensioni. Sorgente luminosa a LED integrato dimmerabile.

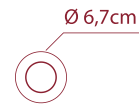

### PL URBMI P

**Source:**  
**LED** 8W - diffused beam - 3000K  
CRI 90 - ~409 lm - 51 lm/W



### COLOURS

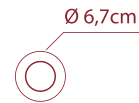
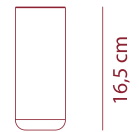

### PL URBMI M

**Source:**  
**LED** 8W - diffused beam - 3000K  
CRI 90 - ~409 lm - 51 lm/W



### COLOURS

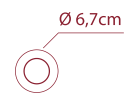

### PL URBMI G

**Source:**  
**LED** 8W - diffused beam - 3000K  
CRI 90 - ~409 lm - 51 lm/W



### COLOURS

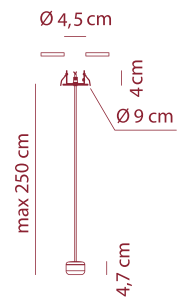

### SP URMI P I recessed downward light only

**Source:**  
**LED** 8W - diffused beam - 3000K  
CRI 90 - ~409 lm - 51 lm/W



### COLOURS



hole Ø 4.5 cm  
min depth 10 cm

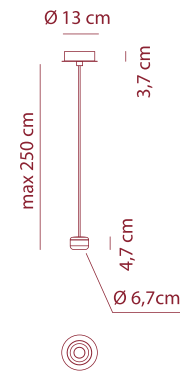

### SP URBMI P downward light only

**Source:**  
**LED** 8W - diffused beam - 3000K  
CRI 90 - ~409 lm - 51 lm/W



### COLOURS

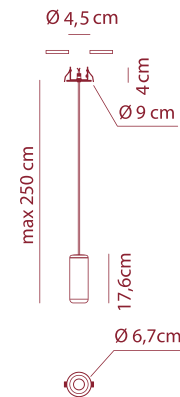

### SP URMI M I recessed downward light only

**Source:**  
**LED** 8W - diffused beam - 3000K  
CRI 90 - ~409 lm - 51 lm/W



### COLOURS



hole Ø 7.5 cm  
min depth 10 cm

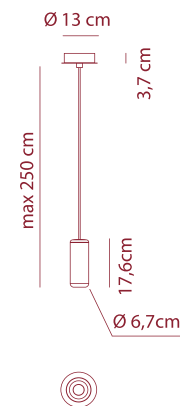

### SP URBMI M downward light only

**Source:**  
**LED** 8W - diffused beam - 3000K  
CRI 90 - ~409 lm - 51 lm/W



### COLOURS

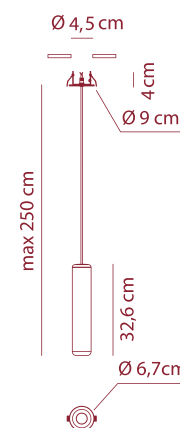

### SP URMI G I recessed downward light only

**Source:**  
**LED** 8W - diffused beam - 3000K  
CRI 90 - ~409 lm - 51 lm/W



### COLOURS



hole Ø 4.5 cm  
min depth 10 cm

## Urban mini

design Dima Loginoff

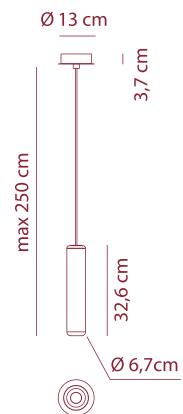

Collection consisting of aluminium ceiling lamps and suspended lamps. Available in several colours and sizes Built-in dimmable LED light source.  
Collezione composta da lampade a sospensione e lampade da soffitto in alluminio. Disponibile in vari colori e dimensioni. Sorgente luminosa a LED integrato dimmerabile.

### SP URBMI G downward light only

**Source:**  
**LED** 8W - diffused beam - 3000K  
CRI 90 - ~409 lm - 51 lm/W



### COLOURS



## Uriel

design Manuel Vivian

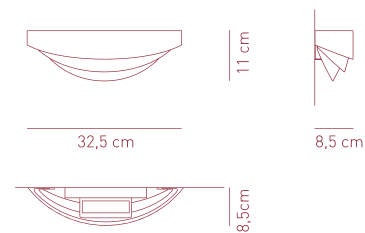

Collection of metal wall lamps in metal. Available in several colours. Light source with R7s fitting.  
Collezione di lampade da parete in metallo, disponibile in vari colori. Sorgente luminosa con attacco R7S.

### AP URIEL P

**Source:**  
**R7S** 1 x Max 120W (78)



### COLOURS

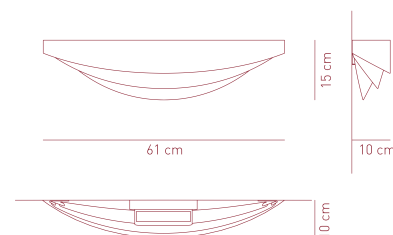
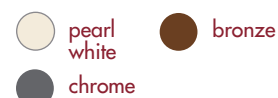

### AP URIEL G

**Source:**  
**R7S** 1 x Max 160W (118)



### COLOURS



## Vasily

design Manuel Vivian

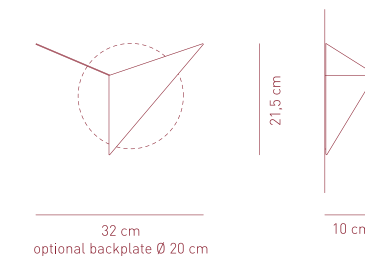

Wall lamp in metal. Available in several colours. Light source with G9 fitting.  
Lampada da parete in metallo, disponibile in vari colori. Sorgente luminosa con attacco G9.

### AP VASILY

**Source:**  
**G9** 1 x Max 60W halo



### COLOURS

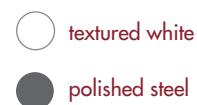

## Velvet

design Manuel Vivian

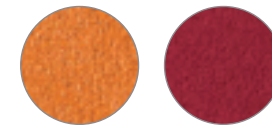

Collection consisting of ceiling lamps and suspended lamps. The cone-shaped lampshade is covered with a flame-retardant Micro 2000 fabric (polyester and cotton), which has a suede effect. Screw fitting or built-in dimmable LED light source.

Collezione di lampade a sospensione e lampade da soffitto con paralume troncoconico in tessuto ignifugato Micro 2000 (poliestere e cotone), effetto scamosciato. Sorgente luminosa con attacco a vite o a LED integrato dimmerabile.

**COMPOSITION/COMPOSIZIONE**  
MICRO 2000 flame retardant fabric - 80% polyester + 20% cotton  
Fleece finishing 100% polyester

Tessuto ignifugato MICRO 2000 - 80% poliestere + 20% cotone  
Effetto scamosciato 100% poliestere

Glow Wire Test (EN 60598-1): 750 °C

**WEIGHT/PESO**  
276 ± 5% gr/m<sup>2</sup>

### AVAILABLE UPON REQUEST

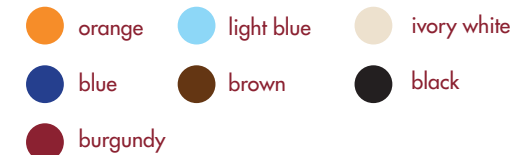

### RADIAL DIFFUSER AVAILABLE UPON REQUEST

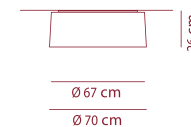

### PL VEL 070

**Source:**  
**E27** 2 x Max 16W LED or  
2 x Max 20W fluo



### COLOUR



### RADIAL DIFFUSER



diffuser included

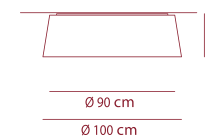

### PL VEL 100

**Source:**  
**E27** 3 x Max 16W LED or  
3 x Max 33W fluo or  
3 x Max 57W halo



### COLOUR

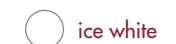

### RADIAL DIFFUSER



diffuser included

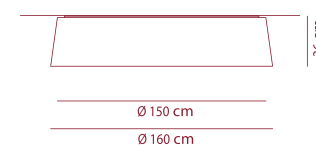

### PL VEL 160

**Source:**  
**E27** 5 x Max 16W LED or  
5 x Max 23W fluo or  
5 x Max 46W halo



### COLOUR

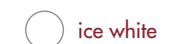

### RADIAL DIFFUSER



diffuser included



## Velvet

design Manuel Vivian

Collection consisting of ceiling lamps and suspended lamps. The cone-shaped lampshade is covered with a flame-retardant Micro 2000 fabric (polyester and cotton), which has a suede effect. Screw fitting or built-in dimmable LED light source.

Collezione di lampade a sospensione e lampade da soffitto con paralume troncoconico in tessuto ignifugato Micro 2000 (poliestere e cotone), effetto scamosciato. Sorgente luminosa con attacco a vite o a LED integrato dimmerabile.

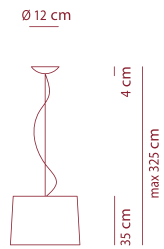

Ø 12 cm  
4 cm  
max 325 cm  
35 cm  
Ø 46 cm  
Ø 50 cm

### SP VEL 050

**Source:**  
**E27** 1 x Max 16W LED or  
1 x Max 23W fluo

CE IP20 +LED

diffuser included

### COLOUR

ice white

### RADIAL DIFFUSER

white

### FINISH

white canopy

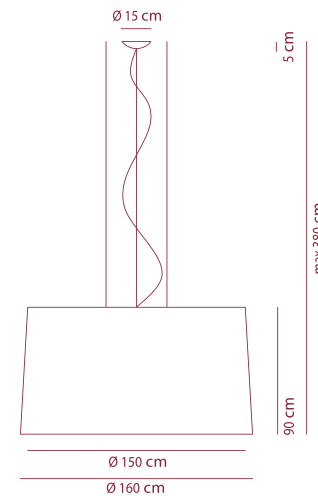

### SP VEL 160 with upward & downward lighting

**Source:**

**E27** 4 x Max 16W + 1 x Max 9,5W LED or  
5 x Max 23W fluo or  
4 x Max 57W + 1 x Max 46W fluo

CE IP20

### SP VEL 160 LED with upward & downward lighting

**Source:**

**LED** 95W - diffused beam - 3000K  
CRI 90 - ~6096 lm - 64 lm/W

CE IP20 dimmable DALI LED

diffuser included

### COLOUR

ice white

### RADIAL DIFFUSER

white

### FINISH

white canopy

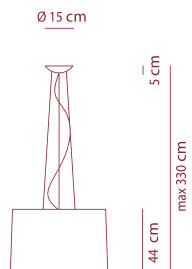

Ø 15 cm  
5 cm  
max 330 cm  
44 cm  
Ø 67 cm  
Ø 70 cm

### SP VEL 070

**Source:**  
**E27** 1 x Max 20W LED or  
1 x Max 33W fluo or  
1 x Max 70W halo

CE IP20 +LED

diffuser included

### COLOUR

ice white

### RADIAL DIFFUSER

white

### FINISH

white canopy

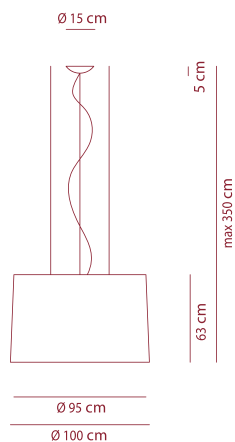

Ø 15 cm  
5 cm  
max 350 cm  
63 cm  
Ø 95 cm  
Ø 100 cm

### SP VEL 100 with upward & downward light

**Source:**  
**E27** 4 x Max 20W LED or  
4 x Max 33W fluo or  
4 x Max 57W halo

CE IP20 +LED

### SP VEL 100 LED with upward & downward light

**Source:**  
**LED** 95W - diffused beam - 3000K  
CRI 90 - ~6378 lm - 67 lm/W

CE IP20 dimmable DALI LED

diffuser included

### COLOUR

ice white

### RADIAL DIFFUSER

white

### FINISH

white canopy

## Virtus

design Manuel Vivian

Collection of suspended lamps in aluminium, also in a recessed version. Available in several colours. Built-in dimmable LED light source.

Lampade a sospensione in alluminio in vari colori. Disponibili anche nella versione ad incasso. Sorgente luminosa a LED integrato dimmerabile.

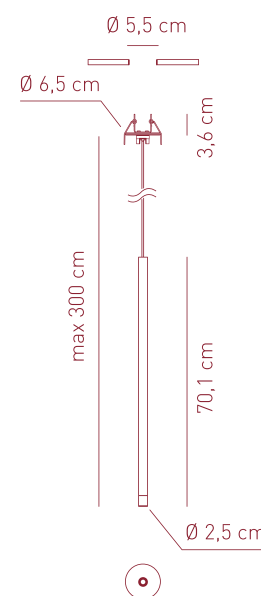
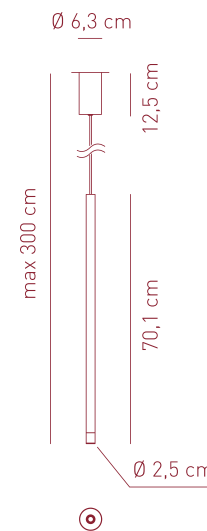

### VIRTUS SUSPENSION mono canopy

**Source:**

**LED** 3W - 3000K  
CRI 90 - ~184 lm - 61 lm/W

CE IP20 LED

### VIRTUS SUSPENSION recessed version

**Source:**

**LED** 3W - 350mA - 3000K  
CRI 90 - ~184 lm - 61 lm/W

CE IP20 with dedicated PSU LED

driver not included

for drivers and dimming technology,  
please refer to our Axo Light pricelist  
or contact our representatives

hole Ø 5.5 cm  
min depth 10 cm

### COLOURS

mat white

anthracite grey wrinkled  
final: black polished nickel

anthracite grey wrinkled  
final: polished gold

rust brown wrinkled  
final: black polished nickel

rust brown wrinkled  
final: polished gold

### COLOURS

mat white

anthracite grey wrinkled  
final: black polished nickel

anthracite grey wrinkled  
final: polished gold

rust brown wrinkled  
final: black polished nickel

rust brown wrinkled  
final: polished gold

# Voluptas

design Lorenzo Truant

Collection of white aluminium wall lamps and ceiling lamps with rubber-coated flexible rod. Available in several versions. Built-in LED light source.

Collezione di lampade da parete e da soffitto in alluminio bianco con asta flessibile rivestita in gomma. Disponibile in varie versioni. Sorgente luminosa a LED integrato.

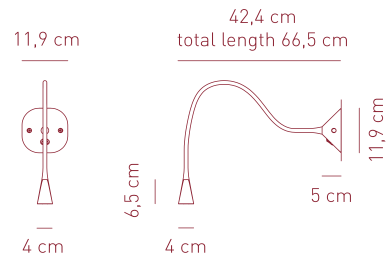

## VOLUPTAS SWITCH WALL

**Source:**  
**LED** 4W - diffused beam - 3000K  
CRI 80 - ~226 lm - 56 lm/W

CE IP20 LED

## COLOURS

○ matt white

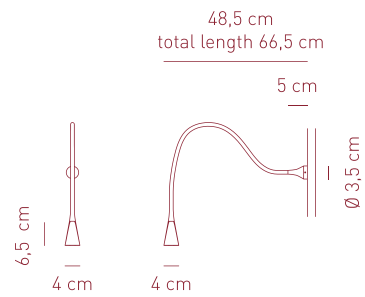

## VOLUPTAS ARM WALL

**Source:**  
**LED** 4W - 700 mA - diffused beam  
- 3000K  
CRI 80 - ~226 lm - 56 lm/W

CE IP20 LED

## COLOURS

○ matt white

driver not included

for drivers and dimming technology, please refer to our Axo Light pricelist or contact our representatives

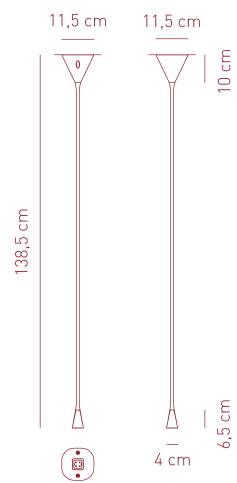

## VOLUPTAS 140 CEILING

**Source:**  
**LED** 16W - diffused beam - 3000K  
CRI 80 - ~226 lm - 56 lm/W

CE IP20 LED

## COLOURS

○ matt white

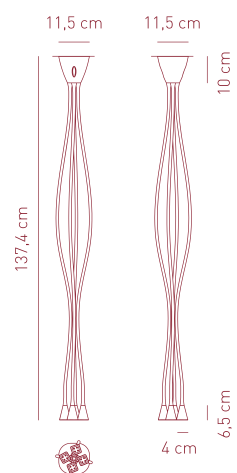

## VOLUPTAS 4-140 CEILING

**Source:**  
**LED** 16W - diffused beam - 3000K  
CRI 80 - ~904 lm - 56 lm/W









CE IP20 LED

## COLOURS

○ matt white



## Legend

- LED** Integrated LED product
- LED** Product for LED light bulbs only
- +LED** Product for LED or conventional light bulbs
- CE** All our products undergo electric safety tests and comply with ECC Directive EN60598-1, LVD 2006/95/EC, EMC 2004/108/EC (where provided)
- CE Intertek** Product in conformity with Intertek certificate for European safety standards
-  Dimmable - dimmer included
-  Dimmable only with dedicated power supply unit
-  Interfaceable with DALI system
-  Dimmable 1-10V
-  Dimmable phase cut
- IPXY** Protection rating against solid bodies X  
– against liquids Y
-  **Class 1**  
Basic insulation, accessible conductors are earthed. Earthing is compulsory
-  **Class 2**  
Double insulation. Earthing: excluded
-  **Class 3**  
Appliance in which protection against electrical shock is guaranteed by the extremely low voltage power supply
- ADA** Product conforms to the USA A.D.A. standards (protruding objects)
- CRI Colour rendering index

Measures of the drawings in cm

---

Axo Light technical sheets and 3D files can be downloaded directly from our website: [www.axolight.it](http://www.axolight.it)

---

## EEL compatibility

### Axo Light – EELc Product List Energy Efficiency Label compatibility (EU Regulation 874/2012)

The Axo Light luminaires are compatible with bulbs – if available in the market and previously checked as regards their dimensions - labelled with the energy classes of the ENERGY LABELLING regulation.

The energy class letter in bold format is related to the bulb supplied together with the specific article.

The products with the symbol **LED** are equipped with built-in LED lamps A, A+, A++ that cannot be changed.

The information regarding the energy classes of the bulbs are not exhaustive about the actual while range available in the Economic European Area market

EELc CODE LIST PRODUCT CODE	EELc
LTAIBUXXXXXXG9L	A, A+, A++
SPALRISHXXXXE27	D, C, B, A, A+, A++
SPANAO90E27	D, C, B, A, A+, A++
SPANAO90FLE	A
SPANAI50E27	D, C, B, A, A+, A++
SPANAI50FLE	A
APAUAXXXXXXE27	D, C, B, A, A+, A++
PLAURAGXXXXXE27	D, C, B, A, A+, A++
PLAURAPXXXXXE27	D, C, B, A, A+, A++
PLAURG30XXXXE27	D, C, B, A, A+, A++
PLAURP30XXXXE27	D, C, B, A, A+, A++
SPAU45/2XXXXE27	D, C, B, A, A+, A++
SPAU60/2XXXXE27	D, C, B, A, A+, A++
SPAURA45XXXXE27	D, C, B, A, A+, A++
SPAURA60XXXXE27	D, C, B, A, A+, A++
SPAX20PIXXXG9X	D
APAX20GRXXXXG9X	D
APAX20PIXXXG9X	D
LTAX20XXXXXXG9X	D
PTAX20XXXXXXG9X	D
PLBEL060E27	D, C, B, A, A+, A++
PLBEL090E27	D, C, B, A, A+, A++
PLBEL118E27	D, C, B, A, A+, A++
PLBEL180E27	D, C, B, A, A+, A++
SPBEL045E27	D, C, B, A, A+, A++
SPBEL060E27	D, C, B, A, A+, A++
SPBEL090E27	D, C, B, A, A+, A++
SPBEL118E27	D, C, B, A, A+, A++
SPBEL180E27	D, C, B, A, A+, A++
APCLAV30XXXXE14	D, C, B, A, A+, A++
APCLAVBRXXXXE14	D, C, B, A, A+, A++
APCLAVGRXXXXE14	D, C, B, A, A+, A++
APCLAVPIXXXE14	D, C, B, A, A+, A++
LTCLAVIGXXXXE27	D, C, B, A, A+, A++
LTCLAVIPXXXXE14	D, C, B, A, A+, A++
LTCLAVPXXXXE14	D, C, B, A, A+, A++
PLCLAV90XXXXE27	D, C, B, A, A+, A++
PLCLAVIUXXXXE27	D, C, B, A, A+, A++
PTCLAVIUXXXXE27	D, C, B, A, A+
SPCLA140XXXXE27	D, C, B, A, A+, A++
SPCLAV40XXXXE27	D, C, B, A, A+, A++
SPCLAV60XXXXE27	D, C, B, A, A+, A++
SPCLAVIPXXXXE27	D, C, B, A, A+, A++
SPCLAVIUXXXXE27	D, C, B, A, A+, A++
SPCLAVIUXXXXFLE	A, A+
SPCL6040XXXXE27	D, C, B, A, A+, A++
SPEXPL10XXXXR7S	D
SPEXPLI5XXXXR7S	D
SPEXPLO5XXXXR7S	D
SPEXPLOXXXXR7S	D
SPEXPQ10XXXXR7S	D
PLEULEGMFLE	A
PLEULEGPFLE	A
PLEULEMPFLE	A
PLEULERGFLE	A
PLEULERMFLE	A
PLEULERPFLE	A
PLEULGMPFLE	A
FAMENCARXXXX12V	C, B
FAMENCARXXXXG9X	D

EELc CODE LIST PRODUCT CODE	EELc
FANASHIRXXXX12V	C, B
FANASHIRXXXXG9X	D
FAFEDORAXXXGU1	A, A+, A++
SPFEDO12XXXXGU1	A, A+, A++
SPFEDOR1XXXXGU1	A, A+, A++
SPFEDOR3XXXXGU1	A, A+, A++
SPFEDOR6XXXXGU1	A, A+, A++
SPFEDOR7XXXXGU1	A, A+, A++
SPLAYAXXE27	D, C, B, A, A+, A++
SPLAYBXXE27	D, C, B, A, A+, A++
SPLAYCXXE27	D, C, B, A, A+, A++
SPLAYDXXE27	D, C, B, A, A+, A++
SPLAYEXXE27	D, C, B, A, A+, A++
SPLAYFXXE27	D, C, B, A, A+, A++
APMELTINXXXXE27	D, C, B, A, A+, A++
PTMELT55XXXXE27	D, C, B, A, A+, A++
PTMELT805NAXXE27	D, C, B, A, A+, A++
SPMEL115XXXXE27	D, C, B, A, A+, A++
SPMEL120XXXXE27	D, C, B, A, A+, A++
SPMELT55XXXXE27	D, C, B, A, A+, A++
SPMELT60XXXXE27	D, C, B, A, A+, A++
SPMELT80XXXXE27	D, C, B, A, A+, A++
LTMUSEGXXXXE27	E, D, C, B, A
LTMUSEPXXXXE14	D, C, B, A, A+, A++
PLMU120QXXXXE27	
+KPLMUSE	A, A+, A++
PLMUS120XXXXE27	
+KPLMUSE	A, A+, A++
PLMU120QXXXXE27	D, C, B, A, A+, A++
PLMUS120XXXXE27	D, C, B, A, A+, A++
PLMUS60QXXXXE27	D, C, B, A, A+, A++
PLMUSE40XXXXE27	D, C, B, A, A+, A++
PLMUSE60XXXXE27	D, C, B, A, A+, A++
PLMUSE80XXXXE27	
+KPLMUSE	A, A+, A++
PLMUSE80XXXXE27	D, C, B, A, A+, A++
SPMUSEXXXXE27	D, C, B, A, A+, A++
PLNAFI3XXXX12V	A, A+, A++
PLNAFIR3XXXXGU1	A, A+, A++
SPNAFIR1XXXXGU1	A, A+, A++
SPNAFIR3XXXXGU1	A, A+, A++
PLNEC100XXXXE27	D, C, B, A, A+, A++
PLNEL140XXXXE27	D, C, B, A, A+, A++
PLNEL60XXXXE27	D, C, B, A, A+, A++
PLNELS60XXXXE27	D, C, B, A, A+, A++
PLNES100XXXXE27	D, C, B, A, A+, A++
PLNES140XXXXE27	D, C, B, A, A+, A++
SPPLU080E27	D, C, B, A, A+, A++
SPPLU120E27	D, C, B, A, A+, A++
SPPLU180E27	D, C, B, A, A+, A++
PTPLU180E27	D, C, B, A, A+, A++
SPSKI070E27	A, A+, A++
SPSKI100E27	A, A+, A++
SPSKI160E27	A, A+, A++
PLSKI070E27	A, A+, A++
PLSKI100E27	A, A+, A++
PLSKI160E27	A, A+, A++
PLSKR070E27	D, C, B, A, A+, A++
SPSK100E27	D, C, B, A, A+, A++
SPSK150E27	D, C, B, A, A+, A++

PRODUCT CODE	EELc
PLSK100E27	D, C, B, A, A+, A++
PLSK150E27	D, C, B, A, A+, A++
PLSKR100E27	D, C, B, A, A+, A++
PLSKR150E27	D, C, B, A, A+, A++
APSKR028FLE	A
SPSKR050E27	D, C, B, A, A+, A++
SPSKR070E27	D, C, B, A, A+, A++
SPSKR100E27	D, C, B, A, A+, A++
SPSKR140E27	D, C, B, A, A+, A++
SPSKR150E27	D, C, B, A, A+, A++
LTSKR050E27	D, C, B, A, A+, A++
PLSPILGIXXX12V	C, B
PLSPILGIXXXG4L	A, A+, A++
PLSPILMIXXX12V	C, B
PLSPILMIXXXG4L	A, A+, A++
PLSPILPIXXX12V	C, B
PLSPILPIXXXG4L	A, A+, A++
APSPILLRXXX12V	C, B
APSPILLRXXXG4L	A, A+, A++
SPSPIL10XXX12V	C, B
SPSPIL10XXXG4L	A, A+, A++
SPSPIL12XXX12V	C, B
SPSPIL12XXXG4L	A, A+, A++
SPSPIL20XXX12V	C, B
SPSPIL26XXX12V	C, B
SPSPIL30XXX12V	C, B
SPSPILGIXXX12V	C, B
SPSPILGIXXXG4L	A, A+, A++
SPSPILL3XXX12V	C, B
SPSPILL3XXXG4L	A, A+, A++
SPSPILL6XXX12V	C, B
SPSPILL6XXXG4L	A, A+, A++
SPSPILLGXXX12V	C, B
SPSPILLGXXXG4L	A, A+, A++
SPSPILLMXXX12V	C, B
SPSPILLMXXXG4L	A, A+, A++
SPSPILLPXXX12V	C, B
SPSPILLPXXXG4L	A, A+, A++
SPSPILMIXXX12V	C, B
SPSPILMIXXXG4L	A, A+, A++
SPSPILPIXXX12V	C, B
SPSPILPIXXXG4L	A, A+, A++
SPSPIRYXXXXE27	D, C, B, A, A+, A++
PLSTO100XXXXE27	D, C, B, A, A+, A++
PLSTOR60XXXXE27	D, C, B, A, A+, A++
PLVEL070E27	D, C, B, A, A+, A++
PLVEL100E27	D, C, B, A, A+, A++
PLVEL160E27	D, C, B, A, A+, A++
PLUKI110XXXXE27	D, C, B, A, A+, A++
PLUKIYOGXXXXE27	D, C, B, A, A+, A++
PLUKIYOPXXXXE27	D, C, B, A, A+, A++
APURIELGXXXXR7S	D, C
APURIELPXXXXR7S	D, C
APVASILYXXXXG9X	D
SPVEL050E27	D, C, B, A, A+, A++
SPVEL070E27	D, C, B, A, A+, A++
SPVEL100E27	D, C, B, A, A+, A++
SPVEL160E27	D, C, B, A, A+, A++
SPVEL160FLE	A



## Catalogue image credits

All photos by @shutterstock unless otherwise stated

### intro, left hand page

art images in collage:

©2017 Fine Art Images/Heritage Images/Scala, Florence, Italy  
Rachel Ruysch “Nature morte aux fruits et au bouquet de fleurs” 1703

©2017 Veneranda Biblioteca Ambrosiana/DeAgostini Picture Library/Scala, Florence, Italy  
Jan Bruegel the Elder, “Vase of Flowers with Jewellery, Coins and Shells” 1606

©2017 White Images/Scala, Florence, Italy  
Ambrosius Bosschaert, the Elder “Still Life with flowers” 1614

### p. 12

Villa / Lucern, Switzerland  
Design: Philippe Stuebi Architekten, Zürich  
Photography: Dominique Marc Wehrli

### p. 17

Zen Barn / Ottawa, Canada  
Design: Rick Shean  
Specifier: Christopher Simmonds Architect Inc.

### p. 21

Showroom  
Photos: Studio 7 srl – Pieve di Soligo (TV), Italy

### p. 22

D-Hotel Maris Lobby / Marmaris, Turkey  
Design: MidekMingu  
Photography: Cemal Emden

### p. 31

Showroom Bonaldo SPA, www.bonaldo.it

### p. 38

Nhow Bar / Milan, Italy  
Design: Karim Rashid  
Photography: Giuseppe Creti

### p. 50

Design: Luciana Bueno, Viviana Monari from “ID design for all”  
Photography: Fernando Napolitano

### p. 55

Terrazza Aperol / Il Mercato del Duomo / Milan, Italy  
Design: Antonio Picciolo

### p. 56

Hotel Nira Montana / La Thuile / Valle d’Aosta  
Project by: Studio Del Portico HYPERLINK www.studiodelportico.it  
Photography: Andrea Martiradonna www.martiradonna.it

### p. 75

Yacht Soya  
Design: Studio A-LAB Arch.  
Marina Grasso, Federica Giovannone www.alabmarine.it

### p. 56; 82; 105; 136; 137;

Private residence, 2016 / Treviso, Italy  
Design: Andrea Rossetti, architect  
Photography: Romandini Florindo

### p. 107

W.O.K., World Oriented Kitchen / Rome, Italy  
Design: Colli + Galliano Architetti  
Lighting Design: Illuminati di G. Ippoliti  
Photography: Matteo Piazza

### p. 111; 120

Project: Agnieszka Cuprys - Wilk studio Archissima / Cracovia, PL  
Interior design: Marek Wilk  
Photography: Przemyslaw Kucinski www.niewformie.pl

### p. 123-124; 190

Eneco Headquarter / Rotterdam, The Netherlands  
Project: Hofman Dujardin Architects  
Interior Designer: Fokkema & Partners Studio  
Lighting Design: Studio Rublek  
Photography: Matthijs van Roon

### p. 126; 234

100% Capri Store/ Miami, USA  
www.100x100capri.it  
Design and photography: Paolo Giachi  
www.paologiachi.it/it

### p. 135

Hotel Scandic Tampere Station / Tampere, Finland  
Design: dSIgn Vertti Kivi & Co., Sabina Dontcheff’s team  
Photography: Okko Oinonen

### p. 149

Showroom  
Photography: Studio 7 srl – Pieve di Soligo (TV), Italy

### p. 167

Apartment Nahimovsky Avenue / Moscow, Russia  
Design: Pro VS Studio www.provsstudio.ru  
Interior designer: Veronika Sudnikova www.houzz.it/pro/veronikasudnikova/veronika-sudnikova  
Photography: Sergey Morgunov

### p. 176

Hotel Waldstätterhof / Brunnen, Svizzera

### p. 181; 185

Double Tree by Hilton Hotel London / London, UK  
Architecture and interior design: Bennetts Associates  
Lighting design: Bennetts Associates with GIA Equation  
Lighting supplier: Light Projects Ltd  
Photography: ©Edmund Sumner

### p. 186

Deloitte Headquarters at the Edge Building  
Amsterdam, The Netherlands  
Project by: PLP Architecture  
Interior Design: Fokkema & Partners Studio  
Lighting Project by: ETK Lighting  
Photos: Lida Chaulet and Ronald Tilleman  
Realization: OVG Real Estate

### p. 188

Private Residence / Lodz Poland  
Kuo Architects

### p. 189

Just Fab Headquarters / El Segundo, California, USA  
Project by: Ehrlich Architects  
Interior Design Studio Moshiri Associates Inc  
Photography: Terrance Williams

### p. 196

Leo Burnett Headquarter / Moscow, Russia  
Architects: Nefa Architects  
Lighting Engineers: Spector LAB  
Project Management: Daria Turkina, Maria Boyko  
General Contractor: Atitoka  
Photography: Alexey Knyazev

### p. 198

ENCORE AT EASTMARK / Mesa, Arizona, USA  
Design: Studio Dwell  
Photography: CDP Commercial

### p. 199

Estrel Congress & Messe Center at Estrel Hotel  
Berlin, Germany  
©Estrel Berlin www.estrel.com/en  
Photography: Philip Koschel www.koschel.de

### p. 209

Daimler AG, Mercedes-Benz, IAA 2013, Abt. BC/BP  
Internationale Automobil Ausstellung (IAA)  
Frankfurt, Germany  
Project: TLD Planungsgruppe GMBH, Wendlingen  
Photography: www.keller-fotografie.de

### p. 210

4Midtown Residences/ Miami, USA  
Design: rs3 Designs - Raymond Jimenez & Shannon Scott  
Lighting Specified by: Planet Lighting - Luis Alejandro Blanco

### p. 211 (top)

Golden Palace Hotel LLC  
http://goldenpalace.am/en/Royal-Suite-hotels-in-armenia

### p. 211 (bottom)

The Plaza Hotel / Istanbul, Turkey  
Design: MidekMingu  
Photography: Cemal Emden

### p. 212

Studio Design Exclusiv  
Chisinau, MD-2012, Republic of Moldova

### p. 229

Restaurant Belvedere / Hergiswil, Switzerland  
Design and photography by: Belvedere, Bel Etage\_Ag

### p. 230-231

Christ Juweliere / Kadewe - Berlin, Germany  
Design: D&L Lichtplanung, Ulrich Wallmeier  
and Köster gmbh & Co Kg  
Photography: Stefan Dauth

### p. 233

Hotel Myriad / Lisbon, Portugal  
Hotel Myriad by Sana Hotels www.myriad.pt

## creative direction/art direction/design/photo illustrations

TEIKNA DESIGN

Claudia Neri, creative/design director

Elisa Stagnoli, design assistant

## editing and coordination

Fabrizio Cettina

## printed and bound in Italy

Grafiche Antiga spa

## Renderings

Nudesign srl

Zenzero & co

Neiko srl

## photolito

Graficart Arti Grafiche srl

Fotolito Quattrifoglio

Studio Varianti

Studio Pointer

## photocredits

Florindo Romandini

Studio Varianti

Studio Pointer

Bluemotion





Axo Light si riserva il diritto di apportare ai modelli, senza alcun preavviso, qualsiasi modifica ritenesse opportuna. Axo Light non risponde per eventuali danni a persone o cose causati da una non corretta installazione dei propri apparecchi d'illuminazione. I dati riportati sono puramente indicativi; è possibile che siano riportati degli errori di stampa.

Axo Light reserves itself the right to introduce any changes to its own models, without prior notice. Axo Light is not liable for injuries or damage due to the incorrect installation of its fixtures. The details given here are intended purely as guidance as errors may have occurred during the printing process. Le schede tecniche dei prodotti Axo Light sono scaricabili direttamente dal nostro sito: [www.axolight.it](http://www.axolight.it)

Axo Light technical sheets can be downloaded directly from our website: [www.axolight.it](http://www.axolight.it)

AXO LIGHT srl  
via Moglianese, 44  
30037 Scorzè (Venezia) Italy  
t. +39 041 5845193  
f +39 041 5845060  
[axolight@axolight.it](mailto:axolight@axolight.it)  
[axolight.it](http://axolight.it)

AXO LIGHT USA INC.  
22 Shelter Rock Lane, Ste #104  
Danbury, CT, 06810 USA  
t +1 (203) 730 0452  
f +1 (203) 730 0460  
[info@axolightusa.com](mailto:info@axolightusa.com)  
[axolightusa.com](http://axolightusa.com)

AXO LIGHT ASIA LIMITED  
RM305-306, Office Building  
No.2 Tiantaiyi Road  
Science Town, Luogang District  
510663 Guangzhou - PRC  
t +86 20 38316571  
f +86 20 38251165  
[axo.asia@axolight.asia](mailto:axo.asia@axolight.asia)  
[axolight.it](http://axolight.it)

**Axolight** bespoke design

Italy  
United States  
China

[axolight.it](http://axolight.it)

